

Circuits Analysis

© David Norris

- Delivery: 90 minutes, 19:00 – 19:45, 10 minute break, 19:55 – 20:40 Beijing time, Monday - Friday
- Learning outcomes:

On successful completion of this module a student will be able to:

- 1 Present, process, analysis and comment on experimental data using the word and excel environment.
- 2 Understand the concepts of vectors, forces and moments; apply Newton's laws of motion and equations of motion to simple mechanical systems; analyse systems with simple harmonic motion.
- 3 Understand electromagnetism, current, voltage and resistance characteristics and components used in electrical circuits and apply Ohms Law and Kirchoff's Law.
- 4 Understand basic thermodynamic concepts of energy, work, heat transfer and thermal conductivity.

About me

- I am a British man and native English Speaker.
- I have a first degree in Electronics (Bsc Electronics) and a masters' degree in Computer Science (Msc Computer Science)
- I currently live in London, UK but I will be relocating to Ouagadougou, Burkina Faso in 2023
- I currently teach English as a foreign language, as well as electronics, mathematics and physics
- I have taught another group similar to this one
- Any questions? Feel free to ask!

Circuits Analysis

- A simplified version of a device for keeping solar pannels aimed at the sun. I intend to set up a solar powered electronic business in Western Africa in the medium term. Used a mictocontroller and stepper motors. Firmware is written in 'C' and can use a time based tracking approach or a maximum power point tracking approach. The power yield of a solar panel is proportional to the cosine of the incident angle.

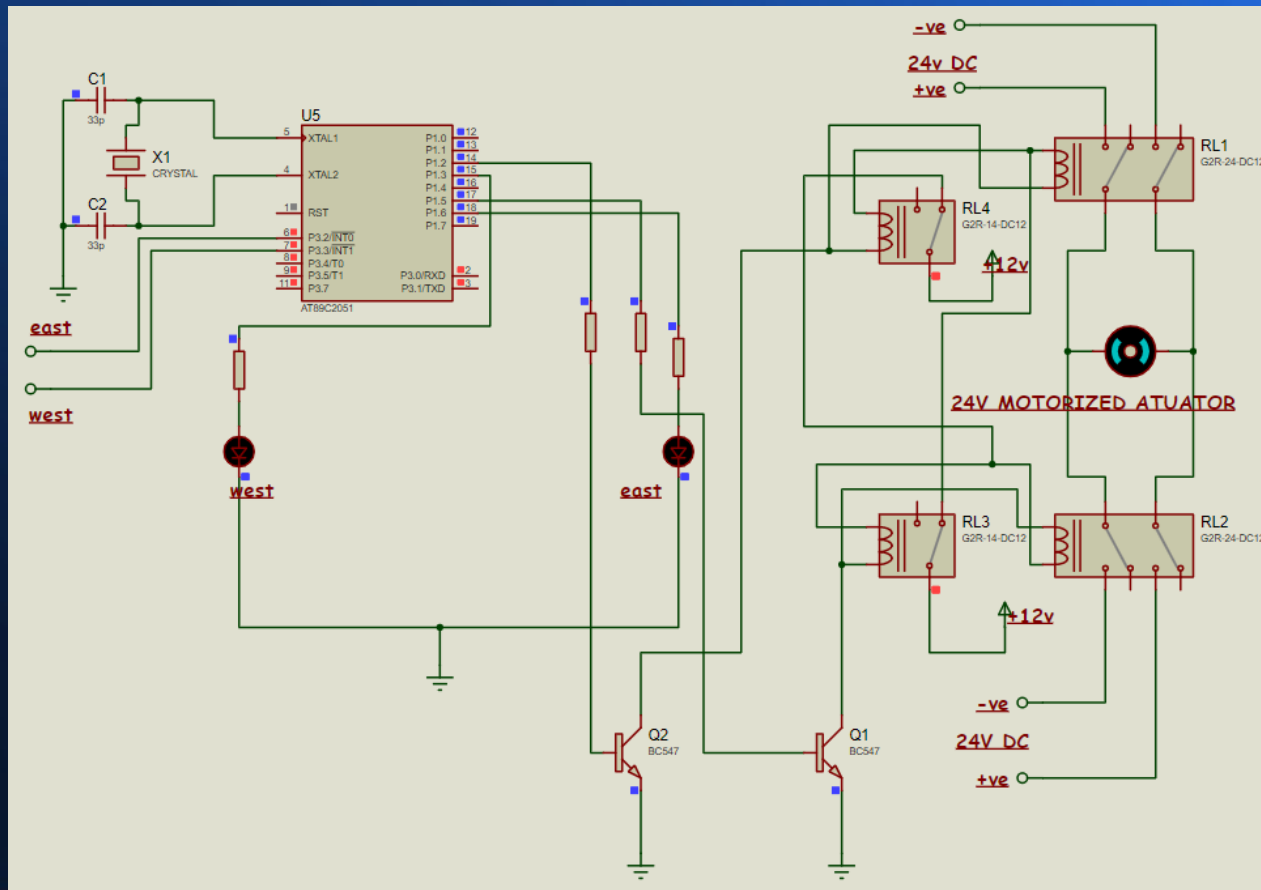

Circuits Analysis

- A low cost Uninterruptible power supply design for use in Western Africa, where I intend to establish a Business. Uses a microcontroller, firmware written in 'C'. Copyright © David Norris, 2021

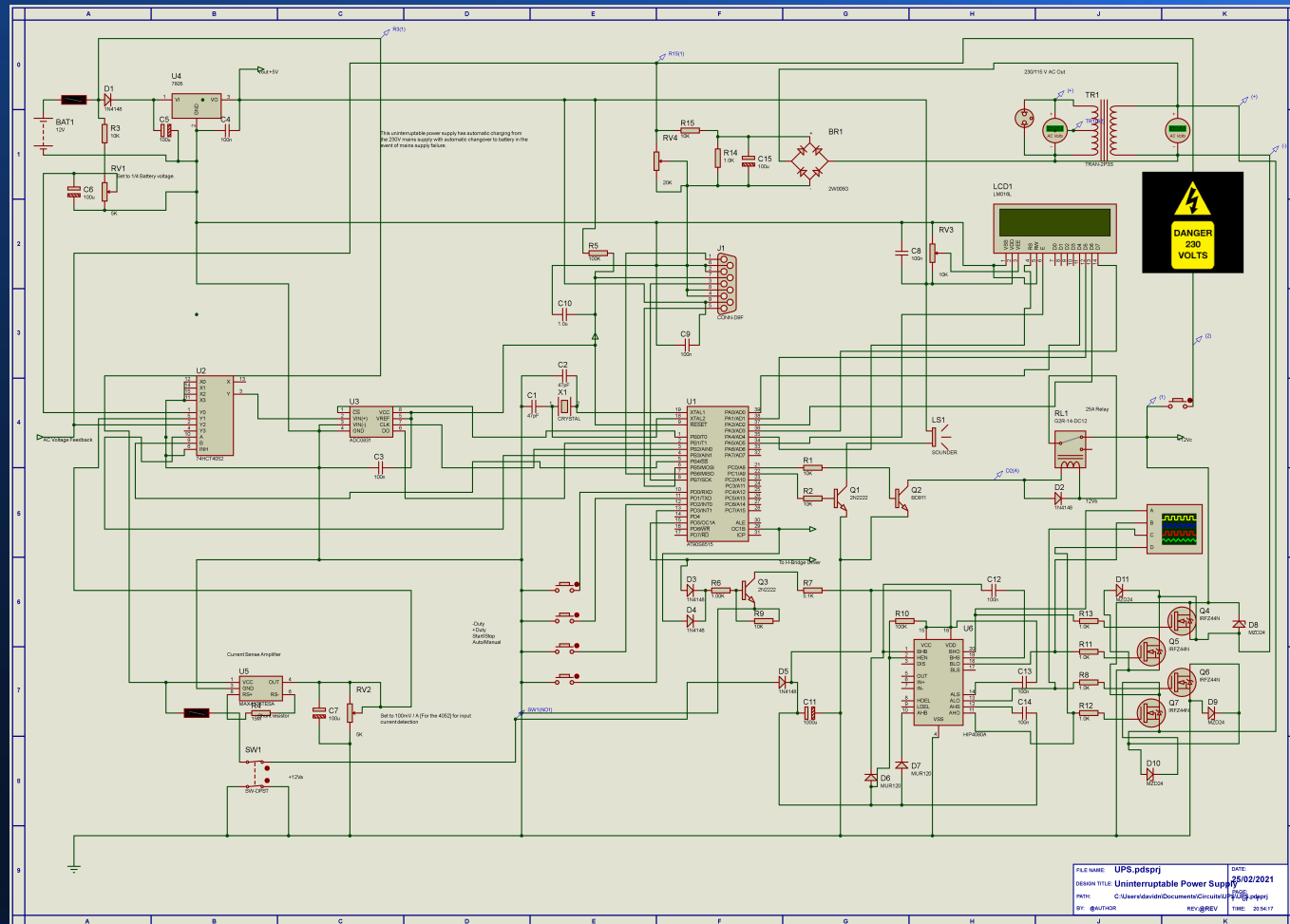

Circuits Analysis

- A boost converter. Before semiconductors, the only way to change DC voltages was to use an inefficient motor/generator. Transformers operate only on AC supplies, and long distance distribution needs high voltage to reduce ohmic cable losses.

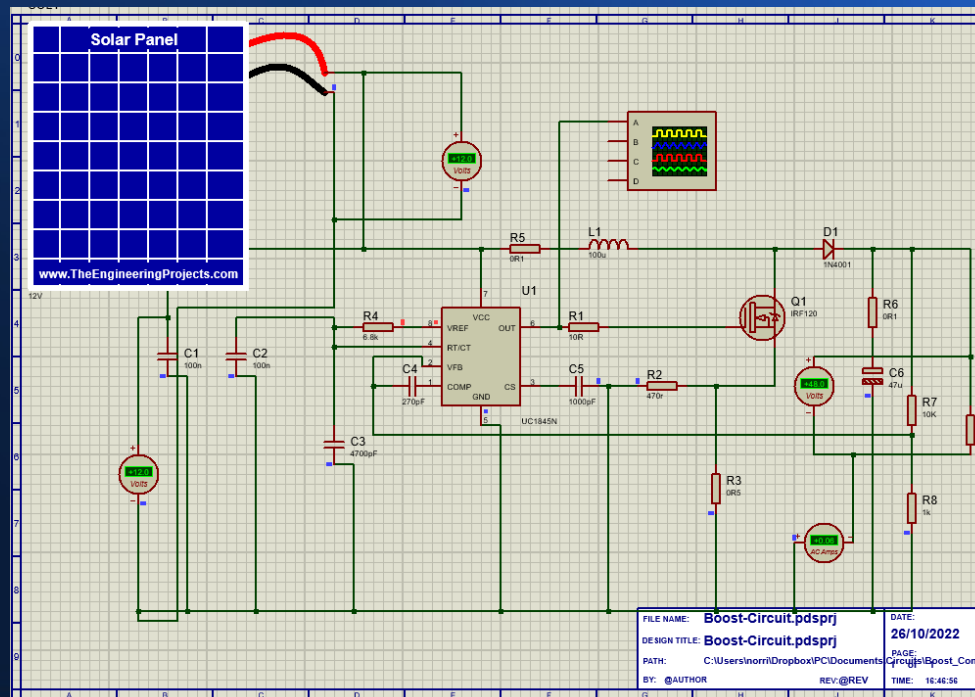

Indicative content

Experimental skills; Engineering units, significant figures, tabulation of data, graph plotting (independent and dependent variables). The use of the Excel environment to plot graphs and charts. The introduction of techniques such as curve fitting, linearization of equations, the use of logarithmic graphs, errors and uncertainties. Awareness of SI derived units (units of measurement derived from the seven base units specified by the International System of Units (SI)).

Mechanical and civil engineering; Vectors, resolving vectors, forces, moments and resultants. Newtons Laws of motion and equations of motion. Kinetic energy, potential energy and momentum.

Electrical and electronic engineering; Atoms and conduction, resistance in electrical circuits. Current, voltage, electrical energy and power. Ohm's Law and Kirchoff's Law.

Chemical and mechanical engineering; Heat transfer, conduction, convection, radiation and thermal conductivity.

Teaching and learning activity

The fundamental concepts with worked examples of the topics will be introduced during the lecture programme. The students learning will be enhanced through laboratory activities and tutorial sessions. The lecture programme will run in parallel with the laboratory programme allowing students to apply their learning simultaneously. The laboratory exercises will consist of experiments which will enable students to apply the skills which they would have developed in the lecture programme. The final three lectures will provide students with an overview of what students should expect to cover in the mechanical engineering, civil engineering, chemical engineering, computing engineering and engineering management programmes.

Assessment

Lab report - 50% LO - 1, 2, 3, 4. Pass mark - 40% 1500 words.

Exam - 50% LO - 1-4 2 hours. Exam will be based on topics covered during the lecture programme.

All elements of summative assessment must be passed to pass the module.

Nature of FORMATIVE assessment supporting student learning:

In-class assignments can be offered to help students grasp concepts introduced during the lectures programme. The feedback from these assignments will allow the teaching team to gauge students' understanding and focus support where required. The teaching team can also offer formative mock exams which will be carried out in-class and/or offered over a timed session via a Module Moodle page. These should mimic exam conditions and difficulties and will help prepare students for the summative exam.

Vectors, Forces & Moments

- Scalars: These are a quantity which has a magnitude, but no direction. For example, temperature is a scalar.
- Vectors: These are quantities which have both a magnitude and a direction. Forces are a vector as they have both magnitude and direction.

Scalars & Vectors: the difference

- Scalars include temperature, distance, speed and mass. These can be measured and have units of measurement. However they are not vectors as they do not have a direction.
- Vectors include displacement, force, velocity and acceleration. (Velocity includes speed and direction, and acceleration is the rate at which velocity is changing.)

How Forces Combine

- If two forces act in the same direction, they simply combine.
- If two forces act in precisely opposite directions, they cancel out.
- If they act at a right angle, we can use trigonometry to calculate the combined force and direction. Right angles are very common in Engineering.
- As we shall see, similar calculations exist in the electrical world (reactance involving inductors and capacitors, where current and voltage are out of phase).

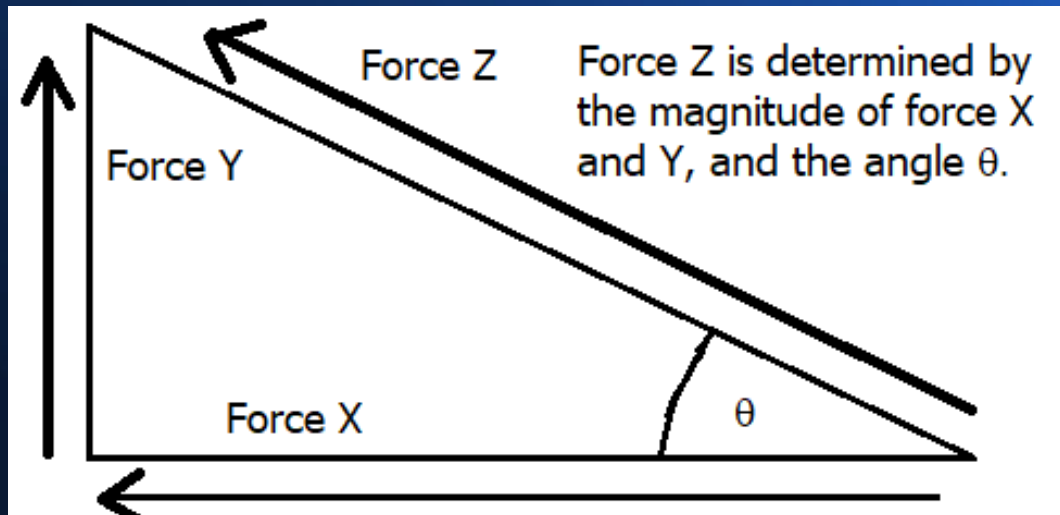

Sine, Cosine and Tangent

- So force X is on the adjacent side to the angle θ .
- Force Y is on the opposite side to θ .
- Force Z is on the Hypotenuse
- A good word to memorise is SOHCAHTOA. This allows you to memorise when to use Sine, Cosine and Tangent.

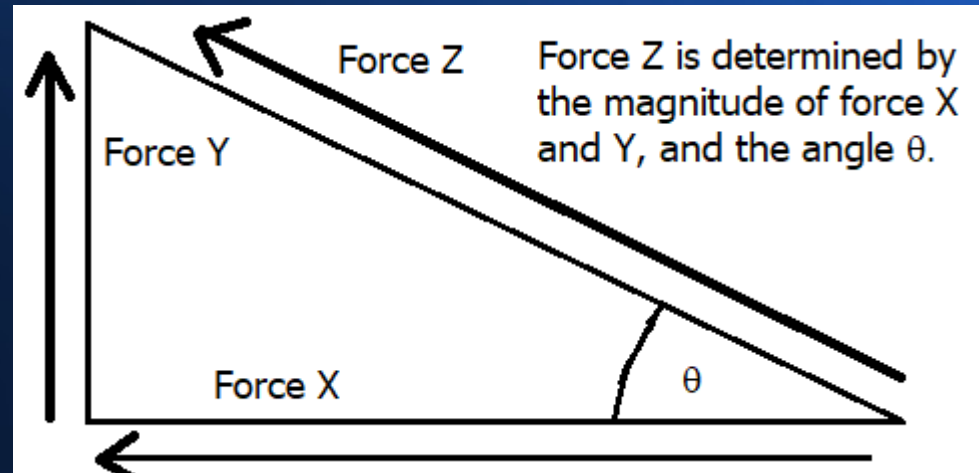

Sine, Cosine and Tangent

- Sine = opposite / Hypotenuse
- Cosine = adjacent / Hypotenuse
- Tangent = opposite / adjacent
- $\theta = \arctan (F_y/F_x)$. (Use Tan-1 on your calculator to get the arctan).
- Applying Pythagorean theorem we know that
- Hypotenuse squared = F_x squared + F_y squared.

So to solve the forces using SOHCAHTOH?

- $F_y = F \sin(\theta)$
- $F_x = F \cos(\theta)$
- $\theta = \arctan(\tan^{-1}) F_y/F_x$

- $F_z = \sqrt{F_x^2 + F_y^2}$

So to solve this example:

- $F_x = F \cos(\theta) = 100\text{N}$
- $\text{Cos } 30^\circ = 86.602\text{N}$
- $F_y = F \sin(\theta) = 100\text{N} \sin 30^\circ = 50\text{N}$
 - Note. $\cos 30^\circ = 0.86602$;
 - $\sin 30^\circ = 0.5$
 - These are multiplied by
Our force of 100N.

A force is a vector.

So let us imagine that force Z is 100 Newtons, at an angle $\theta = 30$ degrees to the

So, how do you calculate what the resulting combined force will be? It will be a vector as it has a magnitude and a direction. And we use trigonometry to solve this.

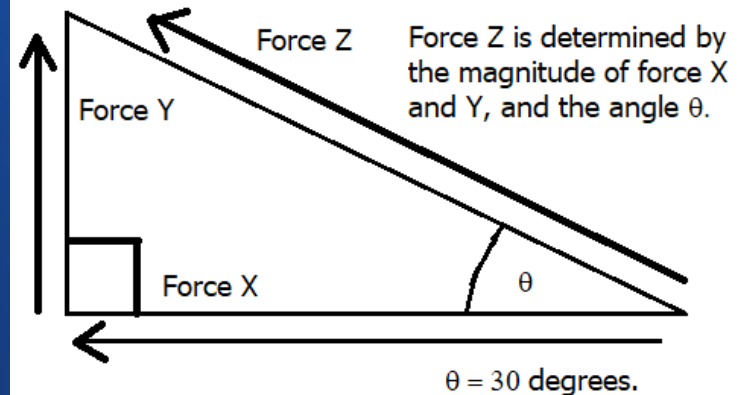

When two forces pull in precisely the same direction, they combine. In opposite directions, they cancel out.

So Force X and Force Y are at 90 degrees to each other.

Solution

I have re-installed the program from yesterday and made it available for you; see <http://dfd.n.line.pm/teaching/Circuits-Analysis.html>

- Solutions: $\theta = \arctan(50/86.602) = 30$ degrees
- $F_z \text{ squared} = 7499.906404 + 2500 = 9999.906$
- $F_z = 100\text{N}$. (Hypotenuse)
- So we have a combined force of 100N at 30 degrees.

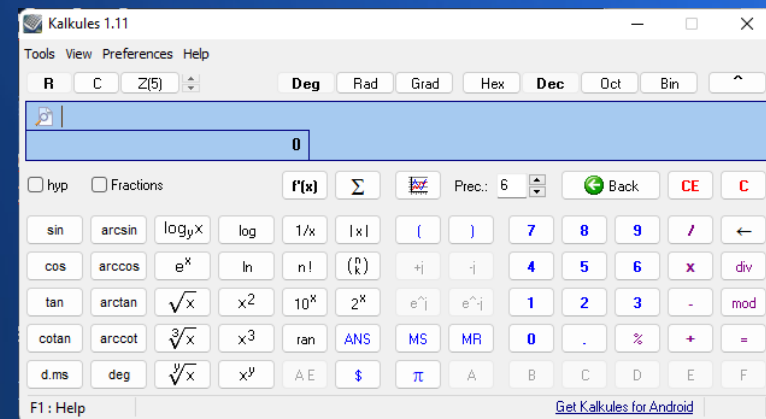

Two ways to express vectors:

- There are two ways to express vectors. For this example, we can use:
- $F_x = 86.6\text{N}$; $F_y = 50\text{N}$; or we can use this form;
- $F = 86.6\mathbf{i} + 50\mathbf{j}$.

The four Equations of Motion

THE FOUR EQUATIONS

● **The four equations of motion are:**

● **$v = u + at$**

● **$s = ut + \frac{1}{2}at^2$**

● **$v^2 = u^2 + 2as$**

● **$s = \frac{1}{2}(u+v)t$**

- u = initial velocity
- v = final velocity
- s = distance travelled
- t = time taken.
- a = **constant** acceleration

Use them only if the acceleration is constant!

Newton's laws of motion

- The first law of motion states that an object at rest will remain at rest, unless acted on by a *net* force.
- If a box of mass 10kg is at rest, it will not move as the forces acting on it are equal. Weight mass (W) = mg – the mass \times the force of gravity. So the force is the force of gravity g (9.81 metres/second²), (we will use ² to mean squared) multiplied by the mass, $10\text{kg} = 98.1\text{N}$.
- So in this example, $W = 98.1\text{N}$.

Newton's first law of motion

- So without a balancing force, the box should be accelerating downwards. It is at rest because the surface it is resting on is providing an equal and opposite force, known as the normal force, which is also 98.1N. So $W - F_n = 0\text{N}$ – they cancel out – $F_{\text{net}} = 0\text{N}$ - keeping the box at rest.
- An object at rest will not move unless a net force is acting on it, so $F_{\text{net}} = 0\text{N}$.

Newton's second law of motion

- Newton's second law of motion states that an object already in motion will remain in motion unless acted on by a net force.
- So if you roll a football across a pitch, why does it come to a stop? Due to friction – this converts kinetic energy to heat energy; friction is thus a net force which opposes the motion of the football. And if played off the ground, gravity and air resistance will bring the ball to a halt. (If another player does not play it first!)

Newton's second law of motion

- $F_{\text{net}} = \text{mass} \times \text{acceleration}$ ($F=MA$).
- If the mass is increased, F_{net} will decrease.
- If the acceleration is increased, F_{net} will increase.
- If the force F_{net} is kept constant, then if the mass is increased, the acceleration will decrease. If the mass is decreased, the acceleration will increase.

Newton's second law of motion

- So lets put some numbers on this. Let us define acceleration.
- $F_{\text{net}} = ma$ is we have seen. It can be expressed also as:
 $F_{\text{net}} = m(\Delta v/\Delta t)$.
- Mass X velocity, $mv = \text{momentum, } p$.
- So $mv = p$. So for example, a train moving at 50kph has more momentum than a car moving at 50kph due to the mass difference. It is easier to stop a car than to stop a train!
- Another way to express this: $m\Delta v = \Delta p$. Or: $F_{\text{net}} = \Delta p/\Delta t$.

Newton's second law of motion

- $F_{\text{net}} = (m\Delta v/\Delta t)\Delta t$, and cancelling Δt gives:
 $m\Delta v$.
- $f\Delta t = m\Delta v$.
- “Impulse” = Δ momentum, Δp .

Newton's third law of motion

- For every action, there is an equal and opposite reaction. So $F_A = -F_B$. For example, if a basketball player, while he jumps in the air, throws the basketball, he applies a force to the ball. But the player is pushed back also, - this is seen if a rifle is fired also – it is known as recoil.
- As the ball has less mass than the player, it experiences more acceleration than the player's acceleration in the opposite direction.

Newton's third law of motion

- If a collision occurs, the two objects experience an equal and opposite force. This seems absurd at first. Consider a fly colliding with a train. The force of, e.g. 0.5N pushing the train backward, is minute compared to the train's momentum, the people on the train do not notice it. The fly experiences a backward force of 0.5N also – a huge force compared to the momentum of the fly, it experiences a huge backward acceleration as it is squashed flat against the windscreen of the train.

Newton's third law of motion

- Let's put numbers on this. Imagine our basketball has a mass of 2kg and our player 100kg. While off the ground, he applies a force of 200N to the ball. Remember, $f = ma$, and $f/m=a$. So for the ball, $200\text{N} / 2\text{kg} = 100\text{m sec}^2$.
- For the player, $200\text{N}/100\text{kg} = 2\text{msec}^2$. It is negative as it is in the opposite direction.

Newton's third law of motion

- Imagine a car travels along a road at a constant speed. What is the horizontal net force acting on the car? If the total frictional force acting on the car is 1500N, what force is the engine applying to the car?
- The car is not accelerating, and so the net force F_{net} must be 0N. As the friction is 1500N, the force applied by the engine must be 1500N for $F_{\text{net}} = 0$.

Newton's third law of motion

- Imagine a force of 200N is applied to a 10kg box across a frictionless surface. If the box accelerates from rest, what is its velocity after 8 seconds?
- How long will it be before it reaches 500m/sec if it continues to accelerate at this rate? $f=ma$ so $f/m=a$. $a=20\text{m/sec}^2$. So $200\text{N} / 10\text{kg} = 20\text{m/sec}^2$.
- After 8 seconds, the velocity increases by 20m/sec, so after 8 seconds it reaches 160m/sec.
- At this rate, $500\text{m/sec} / 20 = 25$ seconds to reach 500m/sec.

Newton's third law of motion

- A force of 300N is applied to a 20kg box. There is a frictional force of 200N. What is the effective force acting on the box? $300\text{N} - 200\text{N}$ give $F_{\text{net}} 100\text{N}$.
- What is the acceleration of the box, and how far will the box travel after 12 seconds after it starts from rest? $F_{\text{net}} = ma$, so $a = 100\text{N} / 20\text{kg}$.
- $a = 100\text{N}/20\text{kg} = 5\text{m}/\text{sec}^2$.
- As for the distance: $V_0 = 0$ as the box is starting from rest. $T = 12$ seconds. So displacement, V_0 is 0, $t = 12$ sec. And distance travelled is d .
- $d = V_0 t + \frac{1}{2} at^2$. This is the equation for displacement.

Newton's third law of motion

- $d = (V_0)(t) + \frac{1}{2}at^2$ gives displacement. $= 0 + (\frac{1}{2}(5)(12))^2$
- $= 0 + \frac{1}{2} \times 5 \times 12 \times 12 = 360\text{m}$ displacement.
- If you plot this on a graph, the distance travelled (displacement, d) is equal to the area under the graph.

Moments

- The turning effect of a force is known as the moment. It is the product of the force multiplied by the perpendicular distance from the line of action of the force to the pivot or point where the object will turn.
- The SI unit of moment of a force is Newton-metre (Nm). It is a vector quantity.
- Its direction is given by the right-hand grip rule perpendicular to the plane of the force and pivot point which is parallel to the axis of rotation.
- $\tau = F \times d$ where τ is the torque, F is the force in Newtons, and d is the distance from the pivot.

Moments

- Example:
- The moment of force of 10 N about a point is 3 Nm. The distance of the point of application of the force from the point is
- Moment of force = force \times distance
- $\Rightarrow 3 \text{ Nm} = 10 \text{ N} \times r$
- $\Rightarrow r = 0.3 \text{ m}$

Moments

- Question:
- If a uniform bar of mass 8 Kg is pivoted at one end, What is the net moment of force on the bar? The only force acting on the bar is gravity.
- Force acting on the bar = $mg = 8\text{kg} \times 9.81 = 78.48\text{N}$
- $= F \times d = 78.48\text{N} \times 8\text{m} = 627.84\text{N!}$
- Have you ever noticed that television aerials, made of aluminium, seem light if held in your hand, yet easily fall down if not very well mounted?
- They are at the top of a long mast, and exposed to the wind. So add weight and wind loading, multiplied by the fact that they are at the 'heavy end' of a long lever – that is a lot of force!

Simple Harmonic Motion

- What is simple harmonic motion? It is defined as, “the motion of something back and forth about a point in a periodic manner”.
- Examples are a weight at the end of a lever (a pendulum), or a mass at the end of a spring. This can be plotted on a graph as a cosine wave – the rate of change is fastest at the mid point and will pass through zero at maximum displacement.
- The frequency of oscillatory motion can be expressed in hertz(Hz) – cycles per second.
- The timeperiod of a swinging pendulum for example, is calculated using: $T = 2\pi(\sqrt{l/g})$. T is the timeperiod, l is the pendulum length in metres, and g the constant of gravity. This is why grandfather clocks are always the same height. Did you know that the timeperiod is determined only by the length of the pendulum, not the mass? Recall that acceleration due to gravity is constant regardless of the mass.

Simple Harmonic motion

- Timeperiod and frequency are reciprocal. So $1/\text{frequency} = \text{timeperiod}$, and $1/\text{timeperiod} = \text{frequency}$.
- Amplitude is the peak displacement.
- Displacement is the maximum distance from the rest point.
- This is a cosine wave.

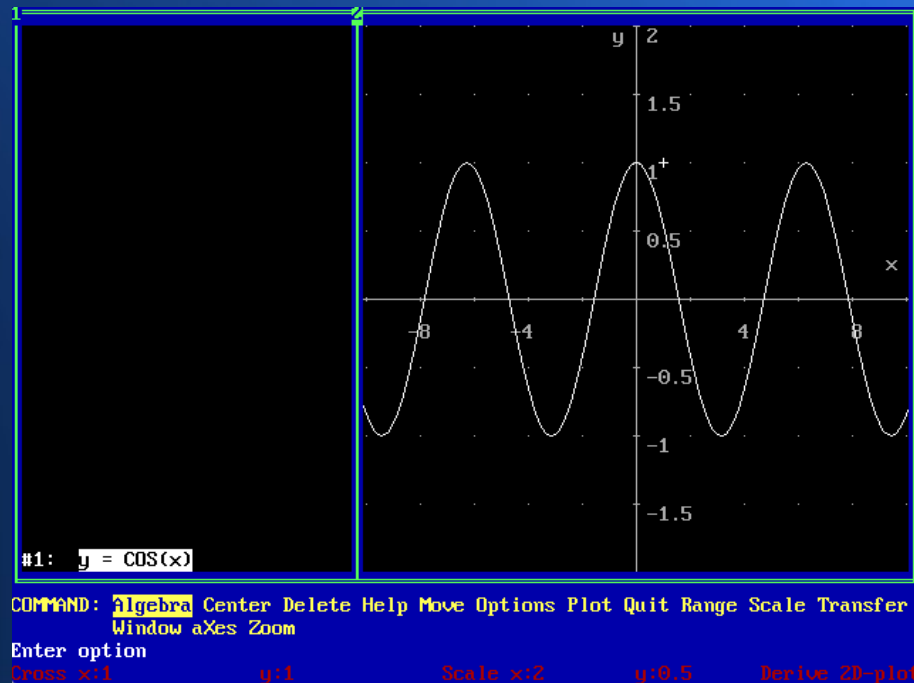

Simple Harmonic Motion

- The shape of the oscillation is a cosine, and the formula is:
- $d(t) = A \cos(\omega t + \phi)$. (Displacement as a function of time).
- So t = timeperiod, A = amplitude, ω = angular frequency (in radians per second please), ϕ is the phase angle.
- Note that $\omega = 2\pi f$ in radians per second.
- For velocity's relationship with time: $v(t) = \omega A \sin(\omega t + \phi)$.
Remember that velocity and displacement are out of phase by 90 degrees or $\pi/2$ radians. So the derivative of $x(t) = A \cos(\omega t + \phi)$ is $a(t) = -\omega^2 A \cos(\omega t + \phi)$. (^ denotes squared).

Simple Harmonic Motion

- Let us look at a weight on a spring. What is the frequency of oscillation?
- Hooke's law states that $F = -kx$ where k is the stiffness of the spring, and $\omega = \sqrt{k/m}$.
- $\omega = 2\pi f$ – this is angular velocity.
- $f = 1/t$. So $\omega = 2\pi/t$.
- Hence $t = 2\pi/\sqrt{k/m}$.

Simple Harmonic Motion

- Now here is an example. Let us think of a pneumatic drill oscillating at 20Hz. What is the acceleration?
- We can simplify the formula for acceleration to $a(t) = -\omega^2 x(t)$.
- What is the acceleration of the head if the oscillation has an amplitude of 5cm?
- Answer:
- The maximum acceleration occurs at the point of maximum velocity - in other words, the centre of the cycle. So, $a = -(40\pi)^2 \times 5 \times 10^{-2} = a = 790\text{ms}^{-2}$.
- Once you've found the acceleration, you can calculate the forces involved - so long as you are told the mass of the head!
- So if the mass of the head is 3kg,
- $F = ma = 3 \times 790 = 2370\text{N}$ – rather a lot of force!

Simple Harmonic motion

- Finding Displacement and Velocity:
- As SHM oscillations follow a sine or cosine wave, we can find the displacement at any point using:
- Where (we use d for displacement): $d(t) = A \cos(2\pi ft)$ or $A \sin(2\pi ft)$ – only difference is the phase measurement. I prefer cosine.
- Please note: A = amplitude - not acceleration!
- Velocity can be found using:
- $v(t) = 2\pi f \sqrt{A^2 - d^2}$.

Simple Harmonic Motion

- $v(t)_{\max} = 2\pi f a$
- $a(t)_{\max} = (2\pi f a)^2 A$
- Damping: In an ideal world, no friction is present. In this case, SHM would continue forever. However, in reality all systems have friction. For example, a pendulum experiences air resistance and friction in the pivot mechanism. So, the oscillatory motion will gradually reduce to 0. So any system in the real world is said to be damped.
- A system with enough friction to cause the oscillation to die away in less than $\frac{1}{4}$ of a cycle is said to be overdamped
- A system where the oscillation takes more than $\frac{1}{4}$ of a cycle is said to be underdamped
- A system where the oscillatory motion dies away in exactly $\frac{1}{4}$ of a cycle is said to be critically damped.

Simple Harmonic Motion

- The effect of damping on SHM.

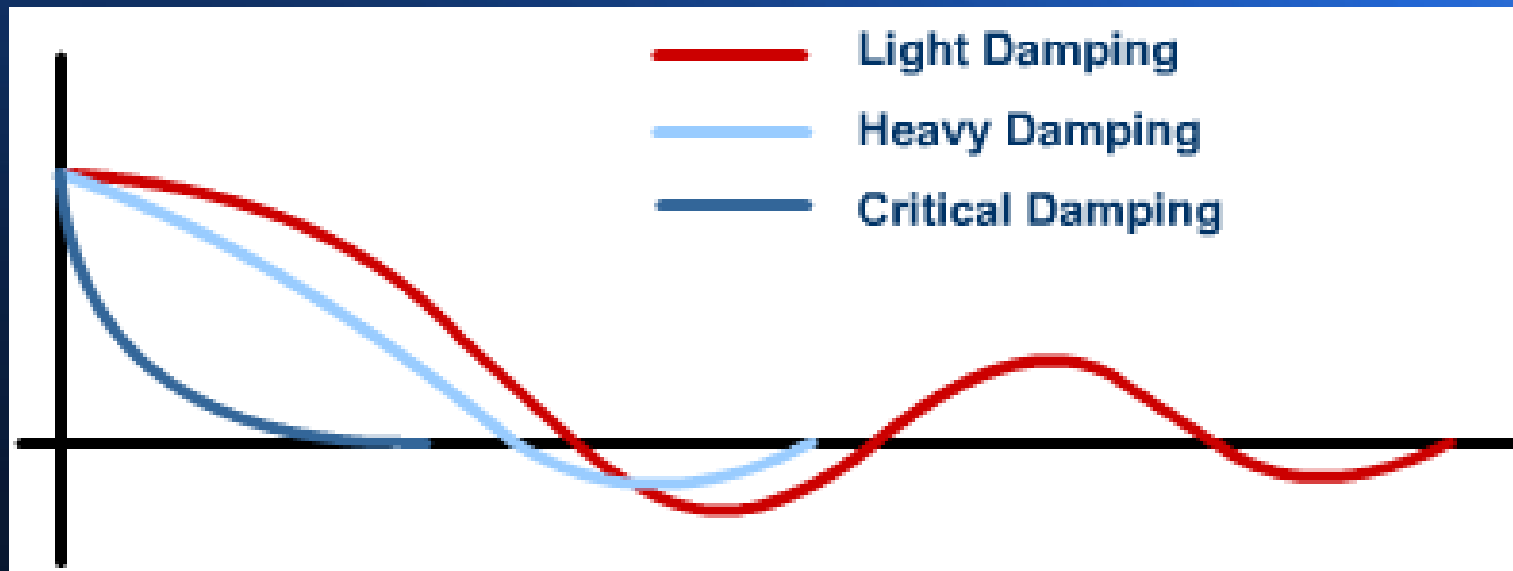

Simple Harmonic Motion

- In many situations damping is desirable. For example, a car suspension includes damping to avoid oscillation continuing after the car hits a bump.
- In other systems, damping is minimised. For example, in a grandfather clock damping is minimised through lubrication. However it cannot be completely eliminated.

Introduction to electrical circuits

- Units of measurement

Quantity	Quantity Symbol	Unit	Unit Symbol	Quantity	Quantity Symbol	Unit	Unit Symbol
Length	l	metre	m	Resistance	R	ohm	Ω
Mass	m	kilogram	kg	Conductance	G	siemen	S
Time	t	second	s	Electromotive force	E	volt	V
Velocity	v	metres per second	m/s or m s^{-1}	Potential difference	V	volt	V
Acceleration	a	metres per second squared	m/s^2 or m s^{-2}	Work	W	joule	J
Force	F	newton	N	Energy	E (or W)	joule	J
Electrical charge or quantity	Q	coulomb	C	Power	P	watt	W
Electric current	I	ampere	A	<p>These are the units we need in our discussion of electrical machines. Please use these symbols to prevent confusion.</p> <p>All of these are S.I units.</p>			

Electrical characteristics

- Electrical characteristics often have physical equivalents in the mechanical world...

Pressure	G/m ²	Electrical pressure	Voltage (V)
Current	Litres/second	Electric current	Amps (I)
Friction	Newtons	Resistance	Ohms (Ω)
Capacity	Litres	Charge	Coulombs (C)
-	-	Power	Watts (W)
Thermal conductance	W/M ² .K	Conductance	Siemens (s)
-	-	Inductance	Hendries (L)

Standard Electronic Component Symbols

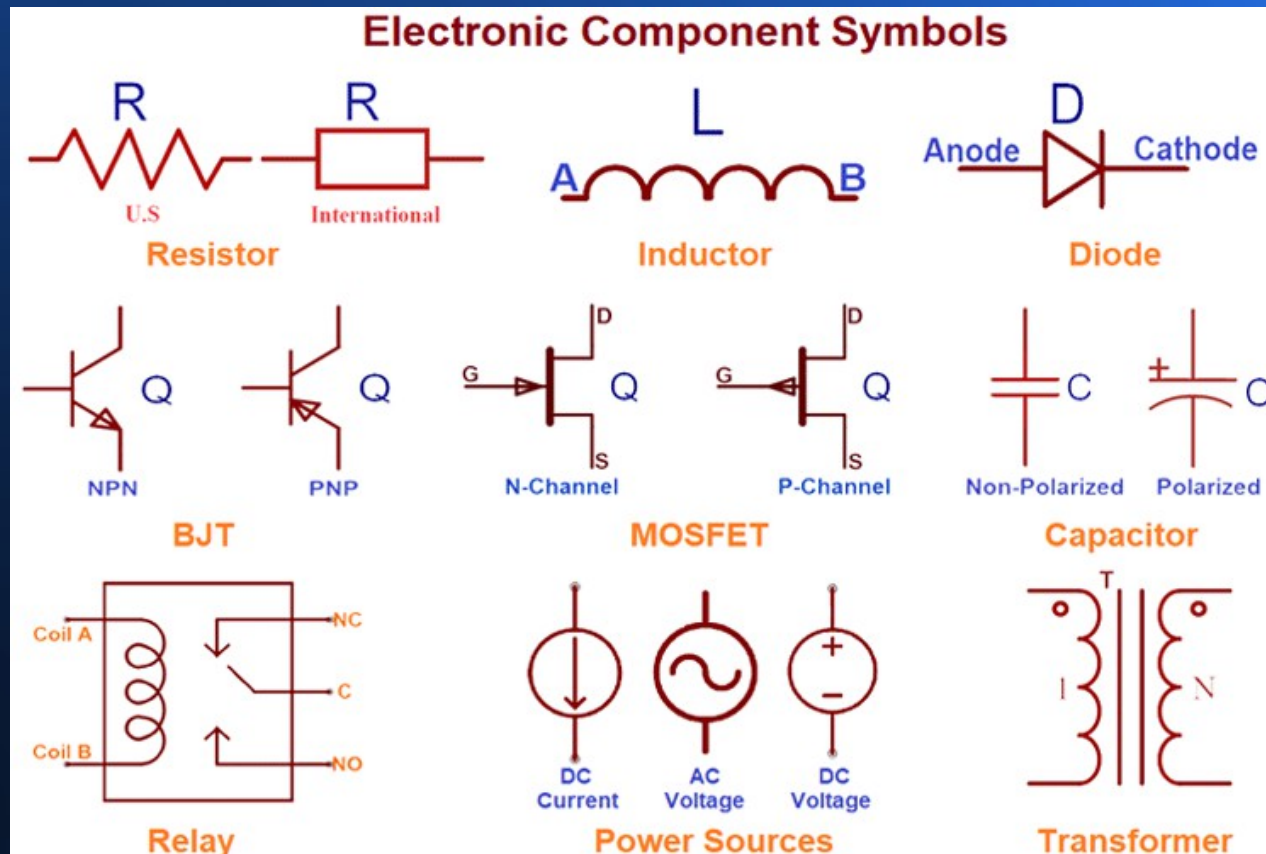

Ohms Law

- Ohm's law
- Ohm's law states that the current I flowing in a circuit:
- is directly proportional to the applied voltage V and
- inversely proportional to the resistance R , provided the
- temperature remains constant. Thus,
- $I = V/R$ or $V = IR$ or $R = V/I$
- This is analogous to current flow in a water pipe. Current flow is proportional to the pressure, and inversely proportional to the force of friction.
- Conductance is the reciprocal of resistance. It is measured in Seimens (S) as $1/R$.

An easy way to remember Ohm's law...

Ohms Law Pie Chart

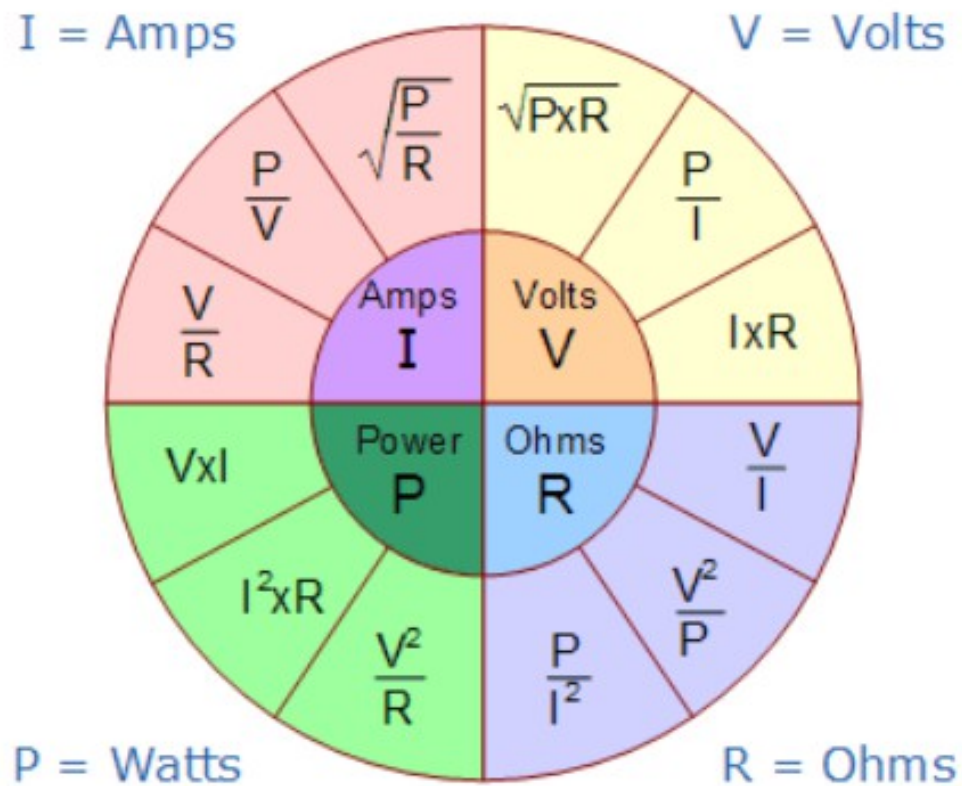

Example of a calculation

- A light emitting diode, l.e.d needs a current limiting resistor to ensure that no more than 20mA flows through the l.e.d (or it will burn out). And the voltage is 9V from a PP3 battery. What is the lowest resistor value we can use? (Note that the l.e.d does not have an ohmic resistance, it introduces a voltage drop in a circuit. It is an example of a non-ohmic device. With no limiting resistor the current flow would be: $9V / 0\Omega = \infty!$. In practice, the maximum current the battery can deliver. This will burn the l.e.d out).
- Referring to ohms law, $R = V/I = 9 \times 0.002 = 4500\Omega$ or 4.5k Ω . As 4.5k Ω is not a preferred value, in practice I would use a 4.7k Ω or 4k7 resistor.
- How can you tell the value of a resistor?

Resistor Colour code

- Our 4k7 resistor will have bands: yellow, purple, brown (the tolerance is not too critical here).

Color	Value	Multiplier	Tolerance
Black	0	$\times 10^0$	$\pm 20\%$
Brown	1	$\times 10^1$	$\pm 1\%$
Red	2	$\times 10^2$	$\pm 2\%$
Orange	3	$\times 10^3$	$\pm 3\%$
Yellow	4	$\times 10^4$	- 0, + 100%
Green	5	$\times 10^5$	$\pm 0.5\%$
Blue	6	$\times 10^6$	$\pm 0.25\%$
Violet	7	$\times 10^7$	$\pm 0.10\%$
Gray	8	$\times 10^8$	$\pm 0.05\%$
White	9	$\times 10^9$	$\pm 10\%$
Gold	-	$\times 10^{-1}$	$\pm 5\%$
Silver	-	$\times 10^{-2}$	$\pm 10\%$

4-band resistor



270 ohms $\pm 5\%$

5-band resistor



100k ohms $\pm 1\%$

Ohms law exercise

- A kettle element is designed to draw 10A of current from the 230V mains supply. Find: the resistance of the element and the power rating of the kettle?
- $R(\Omega) = V/I = 230/10 = 23\Omega$
- Power (W) = $VI = 230V \times 10A = 2300W$ or 2.3KW.

Inductance and Capacitance as a second order system

- Inductance and capacitance together can form a second order system (as inductance and capacitance are both forms of energy storage) - in which a resonance can occur. This is an electrical equivalent of simple harmonic motion.
- The series resistor will provide 'electrical friction' and hence damping.

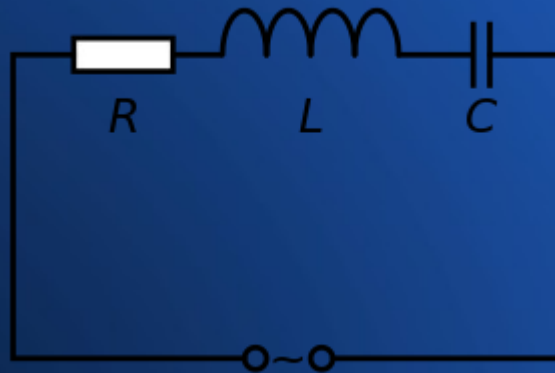

- The resonant frequency can be calculated using the formula: $f = 1 / (2 * \pi * \sqrt{L * C})$.

Capacitance

- Capacitance is the ratio of the amount of electric charge stored on a conductor to a difference in electric potential.
- Typically, two conductors are used to separate electric charge, with one conductor being positively charged and the other negatively charged, but the system having a total charge of zero. The ratio in this case is the magnitude of the electric charge on either conductor and the potential difference measured between the two conductors.
- The capacitance is a function only of the geometry of the design (the area of the plates and the distance between them) and the permittivity of the dielectric material between the plates of the capacitor. For many dielectric materials, the permittivity and thus the capacitance, is independent of the potential difference between the conductors and the total charge on them.
- The unit of capacitance is the Farad (F). A 1 farad capacitor, when charged with 1 coulomb of electrical charge, has a potential difference of 1 volt between its plates. The reciprocal of capacitance is called elastance. The formula for calculating capacitive reactance is: $X_c = 1 / (2\pi f C)$ where f is in hertz, C in farads.
- The Farad is, in practice, a very large unit, so most values are in μF , nF and even pF .

Inductance

- Inductance is: the tendency of an electrical conductor to oppose a change in the electric current flowing through it. The flow of electric current creates a magnetic field around the conductor. The field strength depends on the magnitude of the current, and follows any changes in current. From Faraday's law of induction, any change in magnetic field through a circuit induces an electromotive force (EMF) (voltage) in the conductors, a process known as electromagnetic induction. This induced voltage created by the changing current has the effect of opposing the change in current. This is stated by Lenz's law, and the voltage is called back EMF.
- In the SI system, the unit of inductance is the henry (H), which is the amount of inductance that causes a voltage of one volt, when the current is changing at a rate of one ampere per second. The unit of inductance is the Hendry (L). Inductive reactance (which opposes current flow) is calculated as $X_L = 2\pi FL$ where F is frequency in hertz, L is in hendries.
- In practice, the Hendry is a very large unit, and practical values are expressed in mH, μH , nH and even pH.

Capacitive Reactance Example

- Capacitive Reactance $X_c = 1 / (2\pi fL)$
- For DC, f is $= 0$ and $X_c = \infty\Omega$. (Any divisor of 0 leads to a ∞ result). So on DC a capacitor simply charges to the supply voltage with a time constant of $T = RC$.
- For 50Hz AC, a 1 μ F capacitor has a reactance of $1 / (2\pi(50)(10^{-6})) = 3.183k\Omega$. This is due to voltage and current being out of phase.

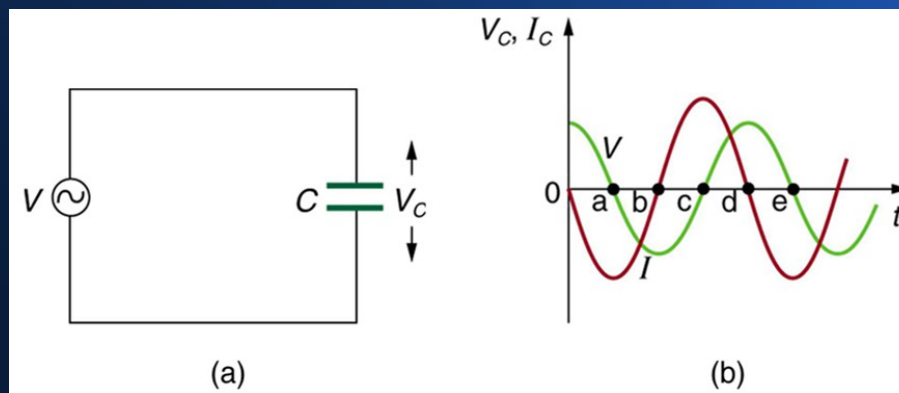

Inductive Reactance Example

- Inductive reactance, $X_L = 2\pi FL$
- For DC, F is $= 0$ and $X_L = 0\Omega$. (Any multiplier of 0 leads to a 0 result). So for DC, an inductor has a reactance of 0Ω and only resistance determines the current – all wire has a little resistance!
- For 50Hz AC, a 1H inductor has an inductive reactance, $X_L = 2\pi(50)(1) = 314.16\Omega$. Note that in a circuit, values in mH or μH are more common; the Henry, like the Farad, is a very large unit indeed!
- For DC, be aware that a momentary transient voltage is induced at the time voltage is applied.

Why resistance, capacitive and inductive reactance are measured in Ohms, Ω

- In this way, once resistance, capacitive reactance and inductive reactance values are known, their effects of limiting current are equivalent and hence, a simple calculation can be carried out; simplifying calculations. Just be aware that resistance is not frequency dependent, but inductive reactance increases in proportion to frequency and capacitive reactance decreases in proportion to to frequency.
- These differences can lead to useful functions, such as in the design of filters. These can separate different signals. And resonance is a very useful characteristic of combining inductance and capacitance values, but this is beyond the scope of this course.
- Be aware however, that these effects are direct equivalents of those which can be found in the mechanical world; a RLC circuit has equivalent characteristics of a damped second order SHM system.

CIVIL – a mnemonic to help you remember...

- In a capacitor, current I leads voltage, V
- In an Inductor, voltage V leads current, I
- This is known as phase difference
- Difference is $\pm 90^\circ$
- A RC combination has $+0-90^\circ$ phase shift
- A RL combination has $-0-90^\circ$ phase shift
- Reactance (Z) is frequency dependent...
- Resistance \mathcal{R} is not – a useful property
- This property is useful in a filter circuit.

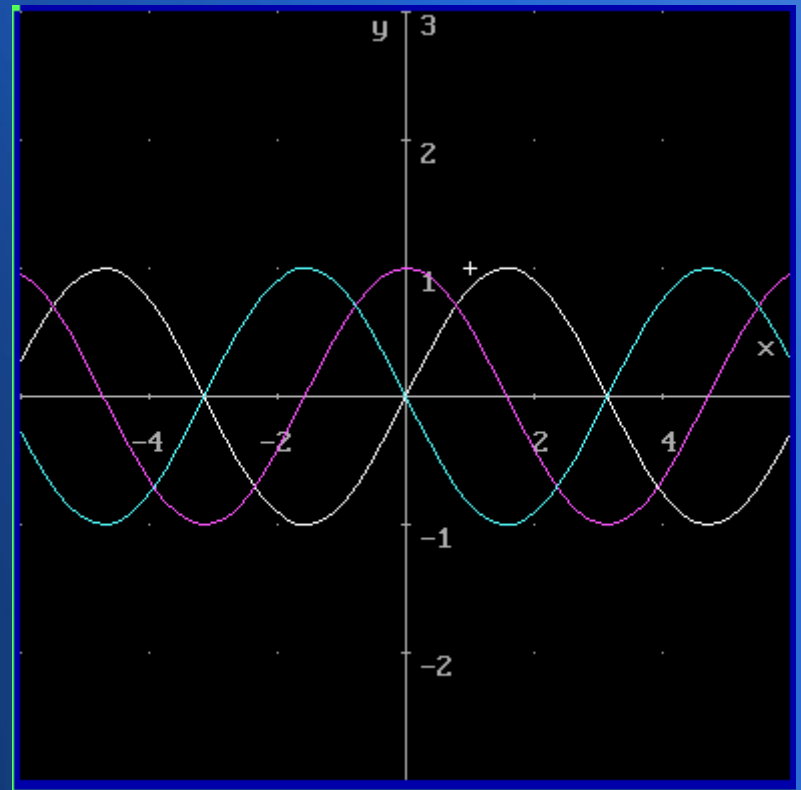

Kirchhoff's Laws | KCL & KVL

- Kirchhoff's Voltage and Current laws:
- Many of the electrical circuits are complex in nature and the computations required to find the unknown quantities in such circuits, using simple ohm's law and series/parallel combination simplifying methods is not possible. Therefore, in order to simplify these circuit calculations, Kirchhoff's laws are used.
- Kirchhoff's Current Law (KCL)
- Kirchhoff's Current Law (KCL) states that the sum of all currents entering and leaving a node in any electrical network is always equal to zero. It is based on the principle of conservation of electric charge. The law is also referred to as Kirchhoff's first law. In formula form this is given by:
- $\sum I = 0$.

Kirchhoff's Laws | KCL & KVL

- Kirchhoff's Voltage Law (KVL)
- The second law is also called Kirchhoff's voltage law (KVL). It states that the sum of the voltage rises and voltage drops over all elements in a closed loop is equal to zero. In formula form:
- $\sum_{i=1}^n V_i = 0$

Kirchov's Voltage Law:

$$\sum_k V_k = 0 \quad \text{where } k = 1, 2, 3, 4, \dots$$
$$V_1 + V_2 + V_3 + V_4 + \dots = 0$$

Kirchov's Current Law:

$$\sum_k i_k = 0 \quad \text{where } k = 1, 2, 3, 4, \dots$$
$$i_1 + i_2 + i_3 + i_4 + \dots = 0$$

What is KVL? (Kirchoff's Voltage Law)

- Kirchoff's laws are not only applicable to DC circuitry, but also works for the AC circuits, when the electromagnetic radiation has large frequency values. In simple words, KVL says that the sum of voltages in an enclosed loop circuit is always equal to zero. By using this law we can easily find different parameters of a circuit like resistance, current or voltage quite easily.

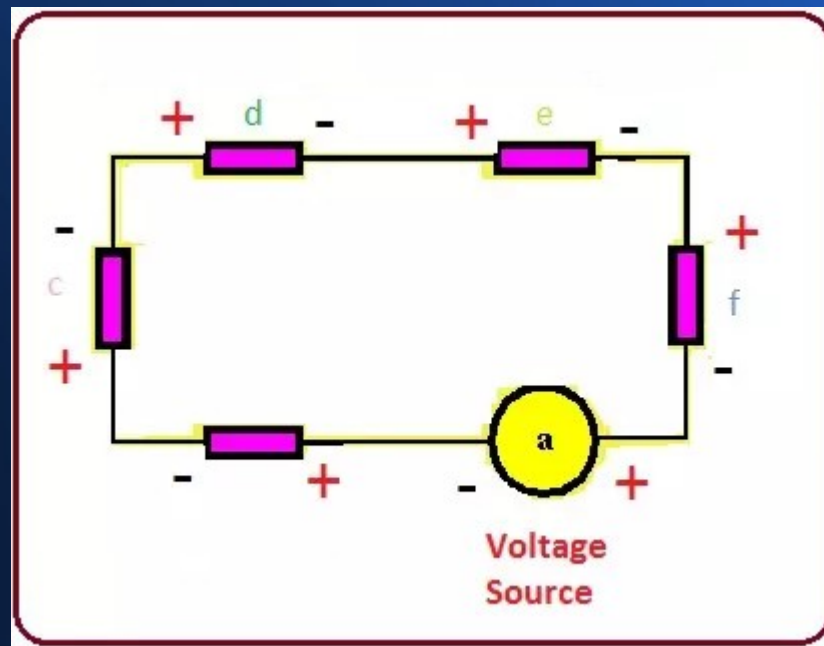

Application of KVL Law

- Mesh Analysis is the method to help us to find the current and voltage in any close-loop working with the KVL, by this analysis we can find values of current and voltage across any component of the loop on the circuit.
- There are three steps to apply this mesh analysis. Which are described here.
- Allocate discrete current values to every enclosed circle of the network.
- After that Apply Kirchhoff voltage law about every enclosed circle of the system.
- And resolve the resultant concurrent linear equations to find the value of current in the ring.

Application of KCL Law

- These are some applications of this law.
- KCL is used to find the different electrical parameter like current, voltage and resistance in different circuits but it mostly used in complex circuits to find electrical parameters.

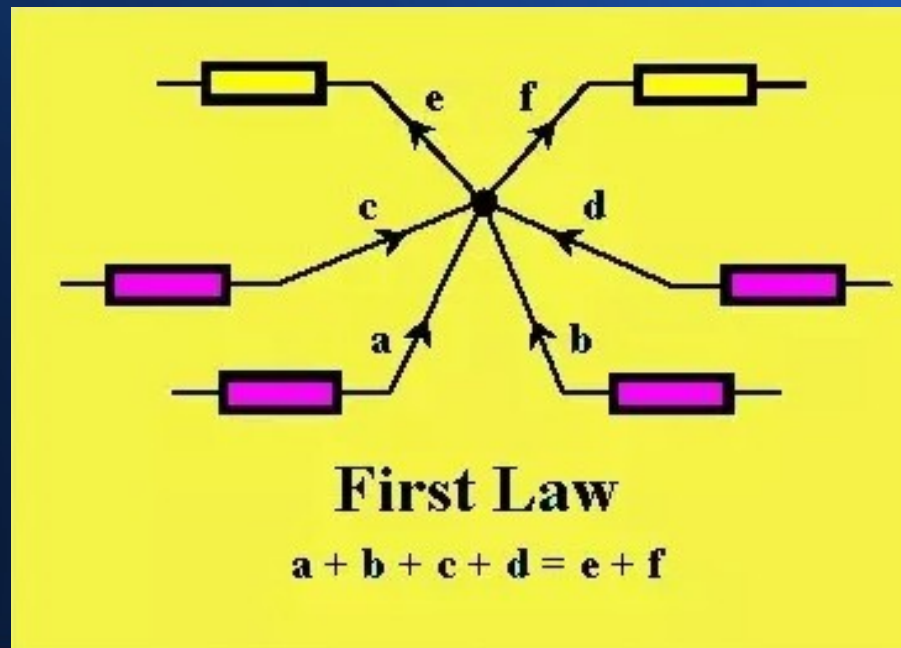

Nodal Analysis

- This method uses KCL to find the value of the voltage at the node and then calculate the values of current and voltage at any component of the circuit.
- There are some steps you should follow to apply this rule which described below.
- To apply this rule, first of all, you should find the no of nodes in a circuit and reference node.
- Then allocate current and its path to every discrete division (branch) of the nodes in the circuit.
- Apply KCL to every node of the circuit.
- Then make equations and resolve them to find the values of current (I) and voltage (V).
- Then find the values of current (I) and voltage (V) at every component of circuitry.

Kirchoff's Law Example: the Wheatstone Bridge

- Bridge circuits are a very common tool in electronics. They are used in measurements, transducers and switching circuits. I had an assignment involving one as an undergraduate. In this example, we will show how to use Kirchoff's laws to determine the current I_5 . The circuit has four bridge sections with resistors $R_1 - R_4$. There is one cross bridge connection with resistor R_5 . The bridge is subject to a constant voltage V and current I .
- The first Kirchoff law (KCL) states that the sum of all currents in one node is zero. So the total current entering must equal the total current leaving – electrons and energy cannot be made or destroyed.

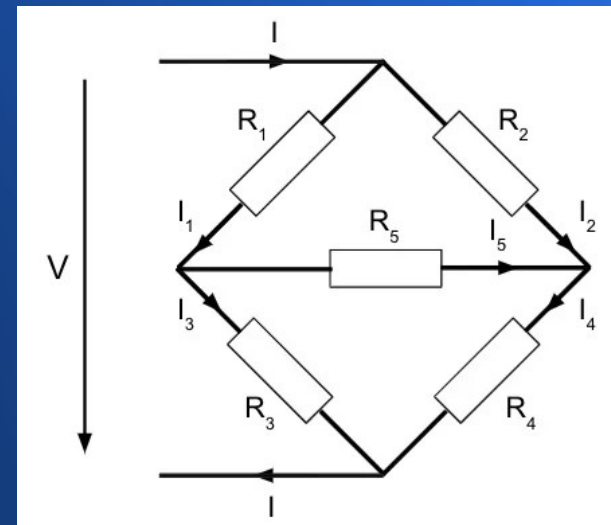

Kirchoff's Law Example: the Wheatstone Bridge

- The first Kirchhoff law (KCL) states that the sum of all currents in one node is zero. In this example:
 - $I = I_1 + I_2$, $I = I_3 + I_4$, $I = I_3 + I_5$
- The second Kirchhoff law (KVL) states the sum of all voltages across all elements in a loop is zero. For this example:
 - $R_1 I_1 + R_3 I_3 - V = 0$;
 - $R_1 I_1 + R_5 I_5 - V - R_2 I_2 = 0$;
 - $R_3 I_3 - R_4 I_4 - R_5 I_5 = 0$.
- The six sets of equations above can be rewritten to find the expression for I_5 (the current in the cross branch):
- The equation shows that for the bridge

to be balanced with a bridge current

$$I_5 = \frac{V(R_2 R_3 - R_1 R_4)}{R_5(R_1 + R_3)(R_2 + R_4) + R_1 R_3(R_2 + R_4) + R_2 R_4(R_1 + R_3)}$$

equal to zero:

$$R_2 R_3 = R_1 R_4.$$

Kirchoff's Law Example: the star-delta (or Y- Δ) conversion

- Kirchoff's laws can be used to convert a star (also known as a Y) connection to a delta connection. For example, this connection is often seen in three phase AC systems, (for example the 400/230V mains supply in the European Union). A widely used application for star delta connections other than three phase transformers, is to limit the starting current of electric motors. The high starting current causes high voltage drops in the power system. As a solution, the motor windings are connected in the star configuration during starting and then change to the delta connection.

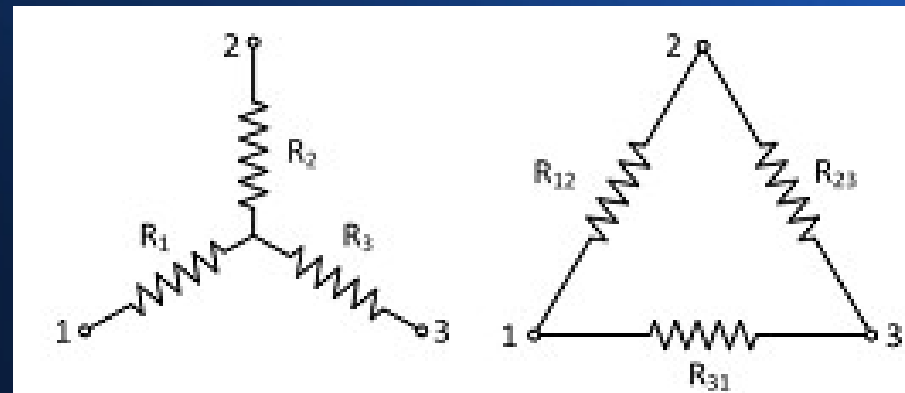

Kirchoff's Law Example: the star-delta (or Y- Δ) conversion

- The star connection as shown in the figure above, has the same voltage drops and currents as the delta connection shown on the right side, only when the following equations are valid:

$$R_1 = \frac{R_{31}R_{12}}{R_{12} + R_{23} + R_{31}}$$

$$R_{12} = R_1 + R_2 + \frac{R_1R_2}{R_3}$$

$$R_2 = \frac{R_{12}R_{23}}{R_{12} + R_{23} + R_{31}}$$

$$R_{23} = R_2 + R_3 + \frac{R_2R_3}{R_1}$$

$$R_3 = \frac{R_{23}R_{31}}{R_{12} + R_{23} + R_{31}}$$

$$R_{31} = R_3 + R_1 + \frac{R_3R_1}{R_2}$$

Series and Parellel resistors

- An illustrated example in Proteus 8.6...

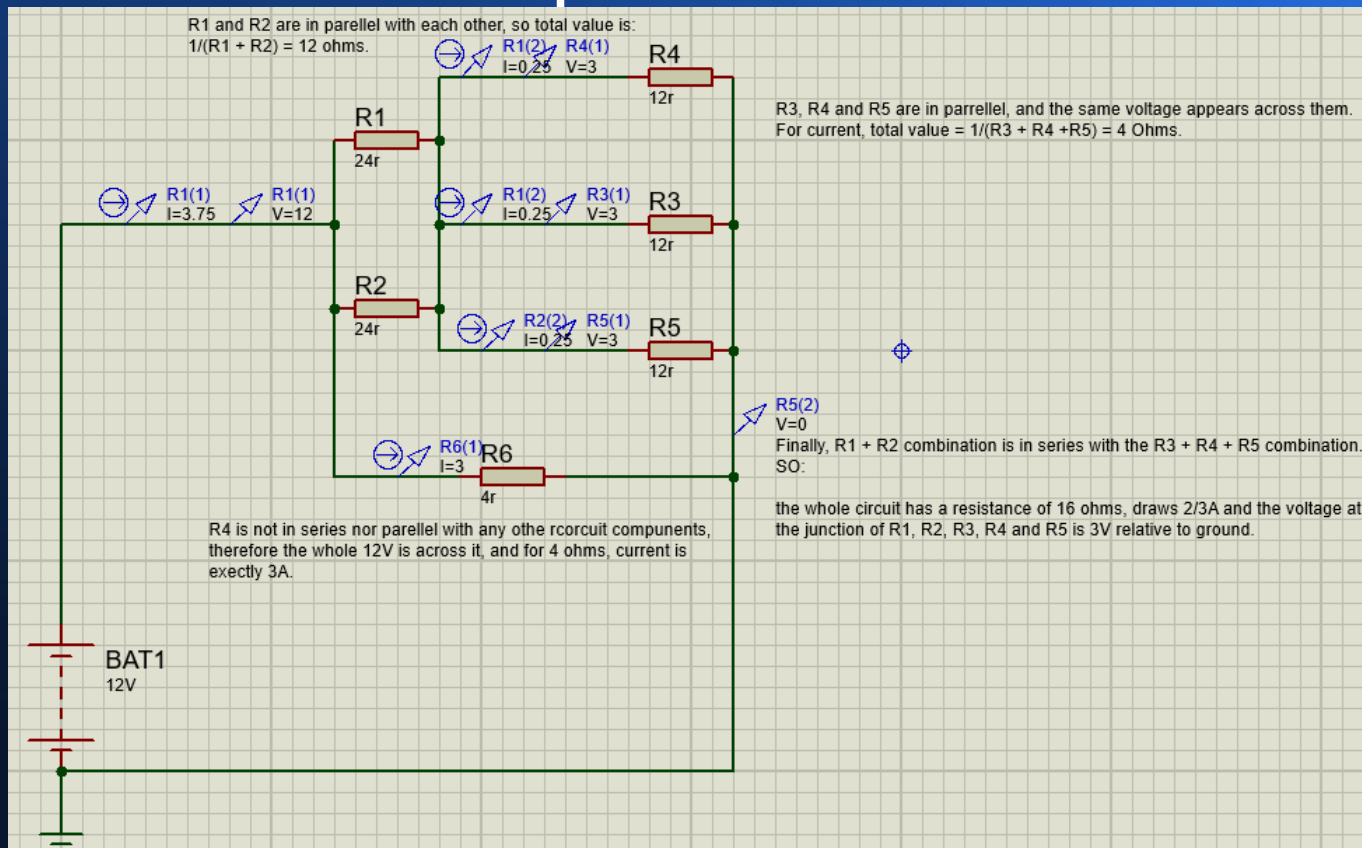

Series and Parellel Rules

- Resistors, series: $R = R1 + R2 + R3 \dots n$
- Resistors, parellel: $R = 1/(R1 + R2, + R3 \dots n)$
- Capacitors, series: $C = 1/(C1 + C2 + C3 \dots n)$
- Capacitors, parellel: $C = C1 + C2 + C3 \dots n$
- Inductors, series: $L = L1 + L2 + L3 \dots n$
- Inductors, parellel: $L = 1/(L1 + L2 + L3 \dots n)$

Impedance and Ohms' Law:

$$Z = \sqrt{X^2 + R^2}$$

- Impedance (Z) is a combined effect of resistance (not frequency dependant) and reactance (frequency dependent).
- Remember, inductive reactance increases with frequency, capacitive reactance decreases with frequency
- At DC, (0Hz) $X_L = 0\Omega$, $X_C = \infty\Omega$
- As current is out of phase by 90 degrees in a capacitor, and -90 degrees in an inductor, pythagoras' theorm can be used to calculate overall impedance.
- Formula for impedance: $Z = \sqrt{X^2 + R^2}$
- Example: if $X_C = 4\Omega$ and $R = 3\Omega$, Then: $Z = \sqrt{4^2 + 3^2} = 5\Omega$
- Sounds familiar? - it is Pythagoras Theorm. We met it in 'resultant forces' earlier!

Impedance Example

- In the example in the last slide, the required value of capacitance to obtain a capacitive reactance of 4Ω at 50Hz (the mains frequency in China – and all of Asia, Europe, Africa and Australasia) would require a capacitance of $795.8\mu\text{F}$.
- North/South American continents use 60Hz please note.
- Be aware that is the reason why inductors and capacitors do not have their reactance printed on them – it depends on the AC frequency!!!
- In principle, equivalent circuits such as filters could use either an inductor or a capacitor. However, as inductors tend to be larger and heavier than a capacitor equivalent in reactance, it is rare to encounter RL circuits in practice, and analogue IC's can contain resistors, capacitors, diodes and transistors, but never include inductors; inductance values at chip scales are so small as to be useless.

Impedance Example

- In our example (capacitive reactance of 4Ω at 50Hz; capacitance of $795.8\mu\text{F}$), rearranging for C gives: $795.8 \mu\text{F} = 1/2\pi(50\text{Hz})(4\Omega)$, remember $C = 1/(2\pi f X_c)$.

Remember, for our impedance calculation $Z = \sqrt{X^2 + R^2}$ can be rearranged as:

$X = -\sqrt{Z^2 - R^2}$. (remember Z is always ≥ 0 ; and of course square roots of any negative value can never exist);

$R = \sqrt{Z^2 - X^2}$.

Remember, a package such as Derive can always check your results!

- I used Derive as an Undergraduate - but other programs are available for all platforms.

```
DOSBox 0.74-3, Cpu speed: 3000 cycles, Frameskip 0, Program: DERIVE

#4: x = 1 / (2 * pi * f * c)
#5: x = 2 * pi * f * l
#6: x = 1 / (2 * pi * 50 * c)
#7: z = sqrt(x^2 + r^2)
#8: x = IF(z >= 0, sqrt(z^2 - r^2))
#9: x = IF(z >= 0, -sqrt(z^2 - r^2))
#10: r = IF(z >= 0, sqrt(z^2 - x^2))
#11: r = IF(z >= 0, -sqrt(z^2 - x^2))

COMMAND: solve Build Calculus Declare Expand Factor Help Jump solve Manage
Options Plot Quit Remove Simplify Transfer Unremove move Window approx
Enter option
Solve(07) Y:\DERIVE\NC.MTH Free:100% Derive Algebra
```

AC Wattage

- In a DC circuit, power (W) = Voltage(V) X Current(I).
- For AC, be aware that reactance complicates matters. If a device includes an inductive and/or capacitance element, the apparent power and real power are different!
- This is because power can only be dissipated in a resistance.
- So the dissipation – except where a load is wholly resistive – can be less than voltage X current! This leads to the term 'power factor'.
- Imagine I put a large capacitor across the AC mains supply. I would draw a huge current, yet dissipate no power. However, it would nonetheless incur losses in the distribution system! Be aware that your electricity provider bills you for apparent power! So - improving power factor is important, particularly for large industrial customers.
- This is why substations include capacitors – transformers are inductive!

This is an example of a capacitor bank, for correcting power factor.

- Power factor will not be in the exam, but be aware that AC power is calculated as $P(W) = P_f VI$. Capacitor banks compensate as a counterbalance for large motors and transformers – which can have huge inductance values!



Wire Resistance

- What is the actual resistance of a piece of wire? The resistance value of a wire depends on all three of the following parameters: resistivity, length and diameter. The formula to calculate wire resistance is as follows:
- $R = \rho (l / A)$
- in which R is the resistance in (Ω),
- ρ is the resistivity of the material ($\Omega \cdot m$),
- l is the length of the material (m),
- A is the cross-sectional area of the material (m^2).
- It follows that a long thin wire has a much higher resistance than a short length of thick cable of the same material.
- In practice performance and economic considerations determine the type of cable used in a given application.

Electrical Resistivity – a brief introduction

- Electrical resistivity is a measure of a material's property to oppose the flow of electric current. This is expressed in Ohm-meters ($\Omega \cdot m$). The symbol of resistivity is usually the Greek letter ρ (rho). A high resistivity means that a material does not conduct electric charge well.
- Electrical resistivity is defined as the relation between the electric field inside a material, and the electric current through it as a consequence:
- $\rho = E/J$ where:
- in which ρ is the resistivity of the material ($\Omega \cdot m$),
- E is the magnitude of the electrical field in the material (V/m),
- J is the magnitude of the electric current density in the material (A/m^2)
- If the electric field (E) through a material is very large and the flow of current (J) is very small, it means that the material has a high resistivity.
- As an example, copper wire has a lower resistivity than nichrome wire (used to make heating elements).

Examples of Resistivity

Material	ρ ($\Omega \cdot m$) at 20°C	σ (S/m) at 20°C	Temperature coefficient (1/°C) $\times 10^{-3}$
Silver	1.59×10^{-8}	6.30×10^7	3.8
Copper	1.68×10^{-8}	5.96×10^7	3.9
Gold	2.44×10^{-8}	4.10×10^7	3.4
Aluminum	2.82×10^{-8}	3.5×10^7	3.9
Tungsten	5.60×10^{-8}	1.79×10^7	4.5
Zinc	5.90×10^{-8}	1.69×10^7	3.7
Nickel	6.99×10^{-8}	1.43×10^7	6
Lithium	9.28×10^{-8}	1.08×10^7	6
Iron	1.0×10^{-7}	1.00×10^7	5
Platinum	1.06×10^{-7}	9.43×10^6	3.9
Tin	1.09×10^{-7}	9.17×10^6	4.5
Lead	2.2×10^{-7}	4.55×10^6	3.9
Manganin	4.82×10^{-7}	2.07×10^6	0.002
Constantan	4.9×10^{-7}	2.04×10^6	0.008
Mercury	9.8×10^{-7}	1.02×10^6	0.9
Nichrome	1.10×10^{-6}	9.09×10^5	0.4
Carbon (amorphous)	5×10^{-4} to 8×10^{-4}	1.25 to 2×10^3	-0.5

Electromagnetism

- A magnet is a material or object that creates a magnetic field. While the magnetic field is completely invisible, it creates a force that pulls on other ferromagnetic materials, such as iron, steel, nickel, and cobalt. It can also attract or repel other magnets (like poles repel, unlike poles attract). While a magnet attracts these examples of magnetic materials, non-magnetic materials, such as rubber, coins, feather and leather, are not attracted. This is a diagram of the field around a simple bar magnet:

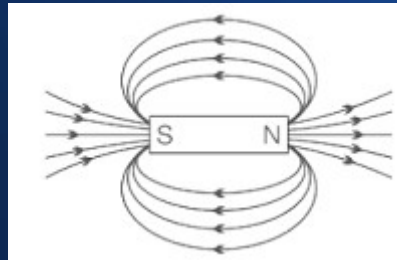

Electromagnetism

- Electric currents typically consist of huge numbers of electric charges that move in a coordinated, overall motion. However, unless you see it heat up and start glowing, it is not easy to tell from the outside whether a wire is carrying a current or not.
- This is because a conductor remains electrically neutral while electrons move through it. Any excess electrons that enter a segment of the wire on one end will simultaneously be made up for by electrons leaving that segment on the other end. Remember, the conductor contains equally many positive charges in the nuclei of its atoms, as there are electrons in it.
- Electromagnetism is the best way to detect and quantify how many amperes of current is going through a circuit. It is created by the motion of the negatively-charged electrons that make up the current, whereas the positively-charged nuclei have no magnetic effect because they are not moving! So while the electric influences of electrons and nuclei cancel out as seen from the outside, their magnetic effects do not.

Electromagnetism

- In a galvanometer (the core of an ammeter), a magnetic field is converted into a force that moves a needle. This is done by exploiting the effect discussed in this text – a current-carrying wire feels a force when it is surrounded by a magnetic field.
- Motors are the most common application of magnetic force on current-carrying wires. Motors have loops of wire in a magnetic field. When current is passed through the loops, the magnetic field exerts torque on the loops, which rotates a shaft. Electrical energy is converted to mechanical work in the process.
- Meters, such as the galvanometer, are another common application of magnetic torque on a current-carrying loop. This finally answers the question how ammeters actually work (we treated them as black boxes in the discussion of circuits earlier). As with motors, the basic idea is to convert the magnetic force into a twisting action, also called torque. This is how the indicator arrow on a meter is made to rotate to a given position, indicating how many amperes are flowing through the meter.

Electromagnetism

- How are electromagnetic fields created in the first place, and what determines their strength?
- An electromagnet uses an electric current to create the same magnetic forces we have just discussed. We use electromagnets for everything from a crane in a scrapyard which lifts scrapped cars, to controlling the beam of a particle accelerator. But if you look at an electromagnet closely, it is nothing but a loop coil of wire, just like the coils we just mentioned in motors and metres.
- How can we use the same device (a coil) for two different purposes: creating a force on a current, as in a motor, and turning a current into a magnetic field?
- Recall Newton's Third Law: every action creates an equal and opposite reaction. In a motor, a magnet created a force on the current-carrying coil via the magnetic field. By Newton's Third Law, the current-carrying coil must simultaneously be exerting a force on the magnet. That is the magnetic field created by the coil, and it makes the coil into an electromagnet.

Electromagnetism and Ampere's Law

- To quantify the strength and direction of the magnetic field created by flowing currents, it is best to start with the simplest case of a straight wire.
- In all cases, the magnetic field is proportional to the current. But the way the magnetic field behaviour depends on your position relative to the wires is very much affected by the geometry of the wires.
- The simplest behaviour is found for a straight wire: the magnetic field in this case decreases inversely with the distance measured perpendicular to the wire.
- Ampère's Law is a discovery André-Marie Ampère made - it is as an example of Newton's Third Law in action, because it puts the "source" and "recipient" of a magnetic force on equal terms -they must be (as action and reaction are equal!).

Electromagnetism – time for some numbers!

- A Tesla is equal to a Newton per meter and ampere. An exemplary example illustrates this: It corresponds exactly to the flux density of a Tesla, which exerts on a 1 meter long electrical conductor, which in turn conducts a current of 1 ampere, exactly 1 Newton attraction.
- The unit Tesla (T) in magnetism: The Tesla was named after the engineer and inventor Nikola Tesla. The definition of the magnetic flux density does not correspond directly to that of the magnetic field. However, it can ultimately be specified in the two quantities (units) Gauss and Tesla. The following relationship applies to convert the Tesla unit:
 - 1 Tesla = 10,000 Gauss
 - 1 T = 1000 mT)
 - 1KG (outside) = 0.1T

Fundamentals of the Tesla Unit and Calculation

- The definition of the magnetic flux density does not correspond to that of the magnetic field. However, it can ultimately be specified in the two quantities (units) Gauss and Tesla. The following relationship applies to convert the Tesla unit:
- 1 Tesla = 10,000 Gauss
- 1 T = 1000 mT (esla)
- 1KG (outside) = 0.1T (Tesla)
- In physics, the magnetic flux density is abbreviated by the letter B. A magnet is ferromagnetic magnetized material. The strength of the magnet is described by Remanence. The units of remanence of a permanent magnet are thus also the units Gauss and Tesla.

The Tesla Unit and Calculation:

- The magnetic flux density can finally be calculated from the force of moving charges. The following relationship applies:
- $1/T = 1(N/Am)$.
- A Tesla is equal to a Newton per meter and ampere. An exemplary example illustrates this: It corresponds exactly to the flux density of a Tesla, which exerts on a 1 meter long electrical conductor, which in turn conducts a current of 1 ampere, exactly 1 Newton attraction. The necessary magnetic field is created by the current flow in the conductor or by the moving electrons.

Fundamentals of the Tesla Unit and Calculation

- From the magnetic flux density B one can determine the magnetic field strength H . The magnetic flux density must be divided by the permeability of a vacuum μ_0 and that of the material μ - for example, the core material of a coil (usually iron in a transformer):
- $H = 1/(\mu * \mu_0) B$

Fundamentals of the Tesla Unit and Calculation

- Definition
- A particle, carrying a charge of one coulomb, and moving perpendicularly through a magnetic field of one tesla, at a speed of one metre per second, experiences a force with magnitude one newton, according to the Lorentz force law. The Tesla, like any S.I unit, can be expressed as:

$$T = \frac{V \cdot s}{m^2} = \frac{N}{A \cdot m} = \frac{J}{A \cdot m^2} = \frac{H \cdot A}{m^2} = \frac{Wb}{m^2} = \frac{kg}{C \cdot s} = \frac{N \cdot s}{C \cdot m} = \frac{kg}{A \cdot s^2}$$

Thermal Characteristics of Materials: chemical and mechanical design

- Many machines which are electrically powered are designed to transfer heat (and/or prevent heat transfer) and this makes thermal design a consideration. Furthermore, waste heat can build up in any machine - as no form of energy conversion is 100% efficient, some energy is lost as heat. Motors, transformers and even electronic components create heat, so thermal design becomes a consideration. For example, your computer requires a cooling fan, and some electronic components – notably power transistors – may need a heatsink to avoid undue heating.
- There are 3 laws of thermodynamics.
- 1st Law of Thermodynamics - Energy cannot be created or destroyed, but can be converted from one form to another;
- 2nd Law of Thermodynamics - For a spontaneous process, the entropy of the universe increases.
- 3rd Law of Thermodynamics - A perfect crystal at zero Kelvin has zero entropy.

Heat transfer mechanisms

- There are broadly four heat transfer mechanisms. The mechanisms of heat transfer are as follows:
- Conduction: This is the transfer of heat (normally through a solid; trapped liquids and gasses conduct poorly). For example, heat generated inside an enclosure is transferred to the outer surface by means of conduction.
- Convection is the transfer of heat from a surface by means of a fluid (liquid or gas). Convection occurs as liquids or gasses are heated: they expand, rise, and are replaced by cooler fluid. The amount of convection may be increased by using a fan to increase the flow.
- Radiation: This is a process where energy is radiated away by means of electromagnetic radiation where an object has a temperature $>$ absolute zero (-273.16°C or 0°K). Although effective for high temperature sources such as the sun, it's less effective for small temperature differences.
- Evaporative cooling: The latent heat of a liquid can be used to transfer heat by absorbing the energy required to evaporate that liquid. The heat absorbed is released by allowing the fluid to condense outside the enclosure – this is how your refrigerator works.

Heat transfer prevention

- In some situations heat transfer is not desirable. As the previous slide shows, heat is transferred in many ways. It has both advantages and disadvantages. Heat transfer can be controlled and prevented by insulation so that it minimises transfer to the environment. The purpose of insulation is to prevent heat transfer from a higher temperature to a lower temperature and therefore all means of heat transfer must be taken into account when designing the insulation. The most important property of insulation is poor thermal conductivity, -a material with poor thermal conductivity acts as a good thermal insulator.
- Because heat transfer can occur in many ways and at the same time in the same object or space, some expertise is needed to ensure that the insulation is done correctly!

Heat transfer prevention

- Examples why you should insulate a building, as an example:
- reduce energy costs
- maintain a certain temperature, e.g., for industrial processes
- prevent freezing of materials
- prevent damaging condensation
- prevent and control fire risk
- improve workplace safety
- reduce noise (due to expansion and contraction of structures).

Thermal Conductivity

- Thermal conduction is the transfer of heat energy by collisions of particles and movement of electrons within a body.
- In the absence of an opposing external driving energy source (such as supplied by the compressor in your refrigerator), within a body or between bodies, temperature differences reduce over time, and thermal equilibrium is approached, with Δt tending towards 0.
- The differential form of Fourier's law of thermal conduction shows that the local heat flux density is equal to: $q = -k\Delta t$ where:
- q is the local heat flux density, W/m^2 ,
- k is the material's conductivity, $W/(m \cdot K)$,
- Δt is the temperature gradient, K/m .

Thermal Conductivity in practice...

- A good insulator will exhibit poor thermal conductance...

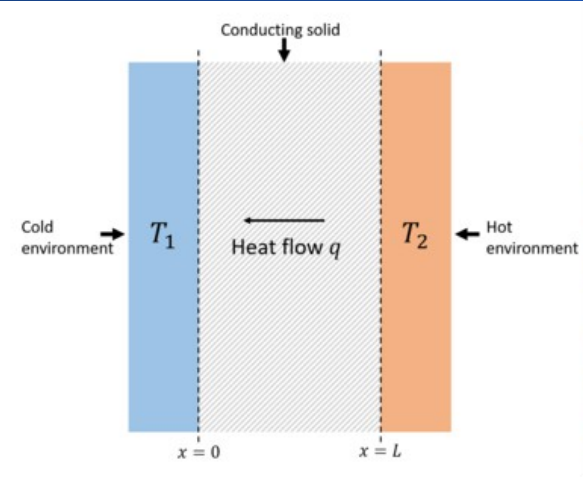

The diagram shows a cross-section of a 'Conducting solid' (hatched area) between two environments. On the left is a 'Cold environment' at temperature T_1 (blue area), and on the right is a 'Hot environment' at temperature T_2 (orange area). The solid is bounded by $x=0$ and $x=L$. An arrow labeled 'Heat flow q ' points from the hot environment through the solid to the cold environment.

$$q = -k \cdot \frac{T_2 - T_1}{L}$$

q = thermal conductivity

$T_2 - T_1$ is the temperature differential

L is the thickness of the conductor.

A is the surface area.

Thermal conductance is defined as kA/L and is measured in watts per degree Kelvin.

Thermal resistance is the inverse of thermal conductance, $L / (kA)$ and is measured in $k.W^{-1}$.

The heat transfer coefficient = k/L , measured in watts per kelvin, $W.K.A^{-1}$ - i.e watts per kelvin per square metre.

Thermal Conductivity Example

- Consider what happens when a layer of ice builds up in a freezer. When this happens, the freezer is much less efficient at keeping food frozen. Under normal operation, a freezer keeps food frozen by transferring heat through the aluminum walls of the freezer. The inside of the freezer is kept at $-10\text{ }^{\circ}\text{C}$; this temperature is maintained by having the other side of the aluminum at a temperature of $-25\text{ }^{\circ}\text{C}$.
-
- The aluminum is 1.5 mm thick. The thermal conductivity of aluminum is $240\text{ J / (s m }^{\circ}\text{C)}$. With a temperature difference of 15° , the amount of heat conducted through the aluminum per second per square meter can be calculated from the conductivity equation:
- $q = k\Delta t/l = 240(15)/0.0015 = 2.4 \times 10^6\text{ J / s m}^2$.
- This is a good heat-transfer rate.

Thermal Conductivity Example

- Consider what happens when a layer of ice builds up in a freezer. When this happens, the freezer is much less efficient at keeping food frozen. Under normal operation, a freezer keeps food frozen by transferring heat through the aluminum walls of the freezer. The inside of the freezer is kept at $-10\text{ }^{\circ}\text{C}$; this temperature is maintained by having the other side of the aluminum at a temperature of $-25\text{ }^{\circ}\text{C}$.
-
- The aluminum is 1.5 mm thick. The thermal conductivity of aluminum is $240\text{ J / (square metres, m }^{\circ}\text{C)}$. With a temperature difference of 15° , the amount of heat conducted through the aluminum per second per square meter can be calculated from the conductivity equation:
- $q = k\Delta t/l = 240(15)/0.0015 = 2.4 \times 10^6\text{ J / s m}^2$.
- This is a good heat-transfer rate.

Thermal Conductivity Example

- Consider what happens when a layer of ice builds up in a freezer. When this happens, the freezer is much less efficient at keeping food frozen. Under normal operation, a freezer keeps food frozen by transferring heat through the aluminum walls of the freezer. The inside of the freezer is kept at $-10\text{ }^{\circ}\text{C}$; this temperature is maintained by having the other side of the aluminum at a temperature of $-25\text{ }^{\circ}\text{C}$.
-
- The aluminum is 1.5 mm thick. The thermal conductivity of aluminum is $240\text{ J / (s m }^{\circ}\text{C)}$. With a temperature difference of 15° , the amount of heat conducted through the aluminum per second per square meter can be calculated from the conductivity equation:
- $q = k\Delta t/l = 240(15)/0.0015 = 2.4 \times 10^6\text{ J / s m}^2$.
- This is a good heat-transfer rate.

Thermal Conductivity Example

- What happens if 5 mm of ice builds up inside the freezer? The heat must now be transferred from the freezer, at $-10\text{ }^{\circ}\text{C}$, through 5 mm of ice, then through 1.5 mm of aluminum, to the outside of the aluminum at $-25\text{ }^{\circ}\text{C}$. The rate of heat transfer must be the same through the ice and the aluminum (as the heat has to pass through both); this allows the temperature at the ice-aluminum interface to be calculated.
- Setting the heat-transfer rates equal gives:
- $k_{\text{ice}} (-10 - T)/l_{\text{ice}} = k_{\text{al}} (T - 25)/l_{\text{al}}$
- The thermal conductivity of ice is $2.2\text{ J / (s m }^{\circ}\text{C)}$.
- Solving for T gives: $T = (-10k_{\text{ice}} / l_{\text{ice}} - 25k_{\text{al}} / l_{\text{al}}) / (k_{\text{ice}} / l_{\text{ice}} + k_{\text{al}} / l_{\text{al}}) = -24.959^{\circ}\text{C}$
- Now, instead of heat being transferred through the aluminum with a temperature difference of 15° , the difference is only 0.041° . This gives a heat transfer rate of:
- $J = kDt/l = 240(0.041) / (0.0015) = 6.6 \times 10^3\text{ J / (s m}^2\text{)}$.
- So with just 5mm of ice covering the walls, the rate of heat transfer is reduced by a factor of more than 300! The freezer has to use much more energy to keep the food cold. This is why manufacturers recommend defrosting regularly.

Thermal Conductivity in practice...

- In heat transfer, the thermal conductivity of a substance, k , is an intensive property that indicates its ability to conduct heat. For most materials, the amount of heat conducted varies with temperature – so in reality, thermal conductivity is non-linear.
- Manganese has the lowest thermal conductivity of any pure metal – $7.81 \text{ Wm}^{-1}\text{k}^{-1}$
- This compares to copper (401), aluminium(247) and Boron arsenide (1300) -the latter is quite remarkable.

Some Basic Components

- **Function of the most Basic Electronic Components**
- **Terminals and Connectors:** Components to make electrical connection.
- **Resistors:** Components used to resist current.
- **Switches:** Components that may be made to either conduct (closed) or not (open).
- **Capacitors:** Components that store electrical charge in an electrical field.
- **Magnetic or Inductive Components:** These are Electrical components that use magnetism such as inductors..
- **Network Components:** Components that use more than 1 type of Passive Component.
- **Piezoelectric devices, crystals, resonators:** Passive components that use piezoelectric. effect.
- **Semiconductors:** Electronic control parts with no moving parts.
- **Diodes:** Components that conduct electricity in only one direction.
- **Transistors:** A semiconductor device capable of amplification.
- **Integrated Circuits or ICs:** A microelectronic computer circuit incorporated into a chip or semiconductor; a whole system rather than a single component.

Some Basic Components



Symbols of Common Components



Diode

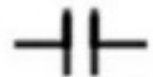

Capacitor



Inductor



Resistor

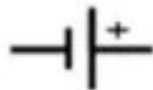

DC voltage source



AC voltage source



And gate



Nand gate



Or gate



Nor gate



Xor gate

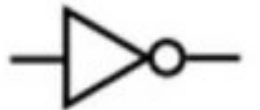

Inverter
(Not gate)



Coil



LED



Transistor



Fuse

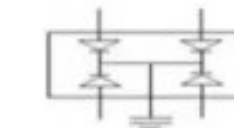

Regulator



Transformer

Opto-electronic (optical electronic) components

- There are various components that can turn light into electricity or vice-versa. Photovoltaic cells (also known as photoelectric cells) generate electric currents when light falls on them and they're used in various types of sensing equipment, including some type of smoke detector. Light-emitting diodes (LEDs) work in the opposite direction, converting small electric currents into light, and are typically used on the instrument panels of audio equipment. Liquid crystal displays (LCDs), such as those used in flatscreen televisions and laptop computers, are more sophisticated examples of opto-electronics.
- On the large scale, photovoltaic cells convert solar energy into electrical energy. I plan to establish a solar powered electronic business in Western Africa.
- And as we are about to see, the sensing/logic/actuation cycle depends heavily on sensors, including optoelectronic devices.

What is the sensing-logic-actuation cycle?

- Electronic devices can sense the world around them, converting a wide variety of physical phenomena into electrical signals that communicate useful information. Such devices (called transducers) have capabilities similar to our own human senses: hearing (microphones), seeing (cameras, including visible light and infrared, and proximity sensors), touch (piezoelectric transducers), and smell and/or taste (chemical sensors).

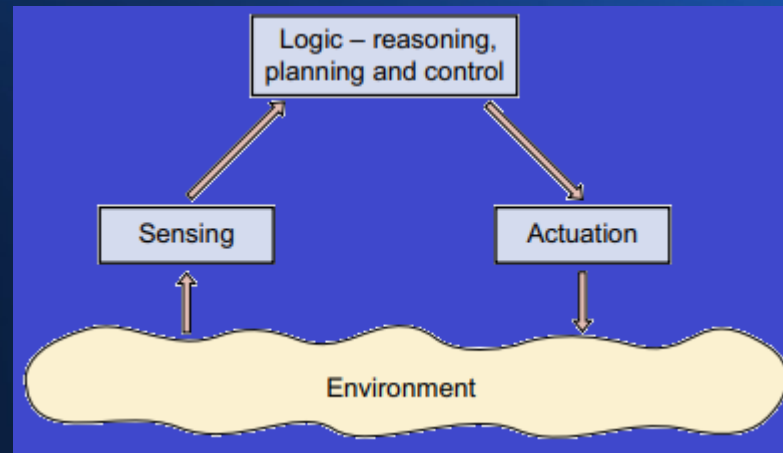

Sensing – a simple example

- A light dependent resistor used as a daylight sensor in a Proteus Simulation. As the sensor is virtual, the torch stands in for actual daylight. A UA741 is configured as a comparator in the following circuit.

This is a simple demonstration of how lighting can be controlled using a light dependent resistor. The LDR serves as a daylight detector.

The idea is that the lighting is triggered automatically when the light falls below a given level. The torch in this demonstration stands in for daylight in this demonstration circuit. And the UA741 operational amplifier here is used as a comparator. The reference voltage is half the supply voltage.

Sensing – Daytime (torch on) – note D1 light emitting diode is OFF.

Once light level reduces the voltage below the reference value of 4.5v, D1 turns off.

An easy way to automate illumination.

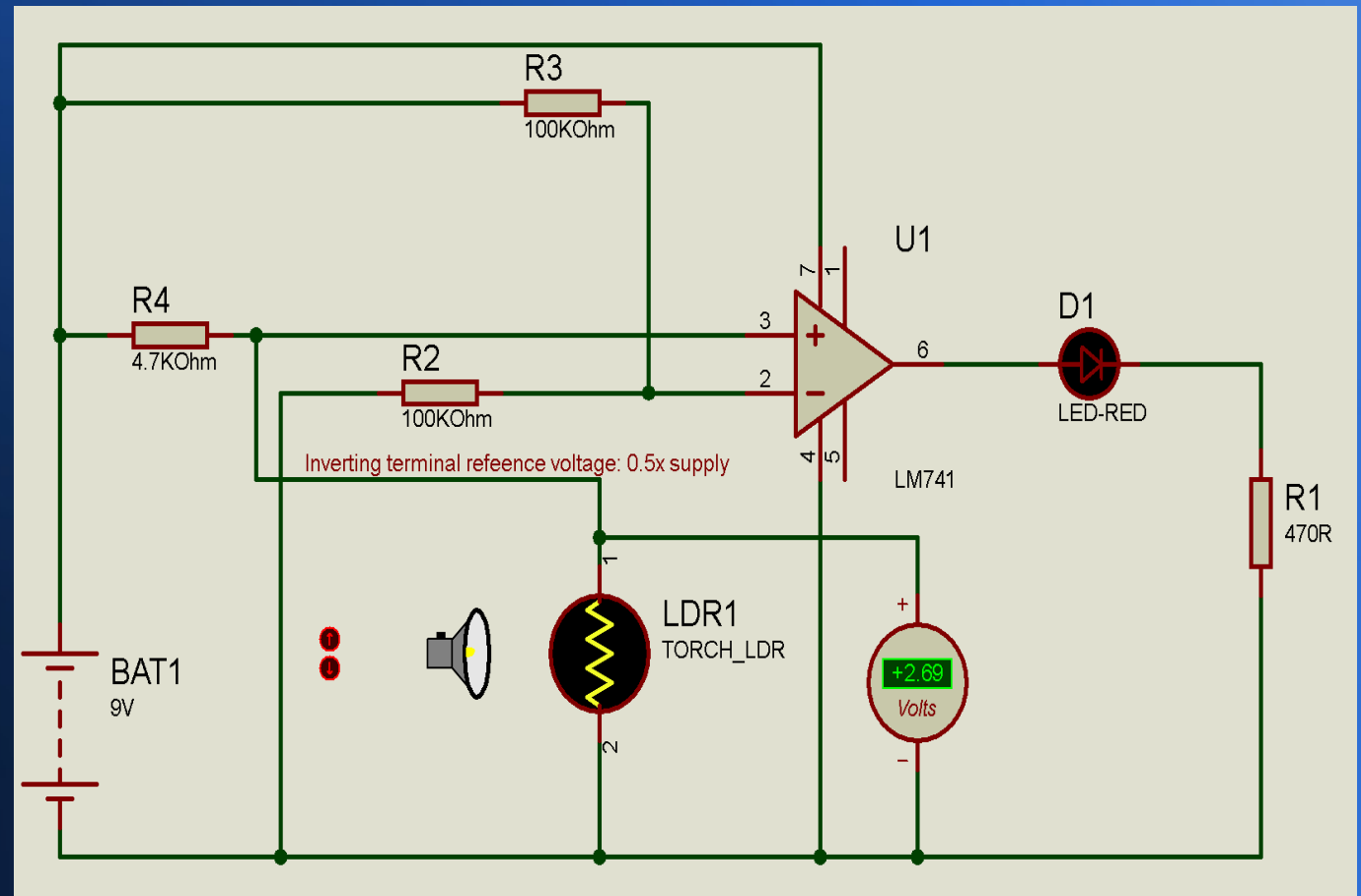

Sensing – Nighttime (torch off) – note D1 light emitting diode is ON.

8.92v is above
the Reference
Voltage.

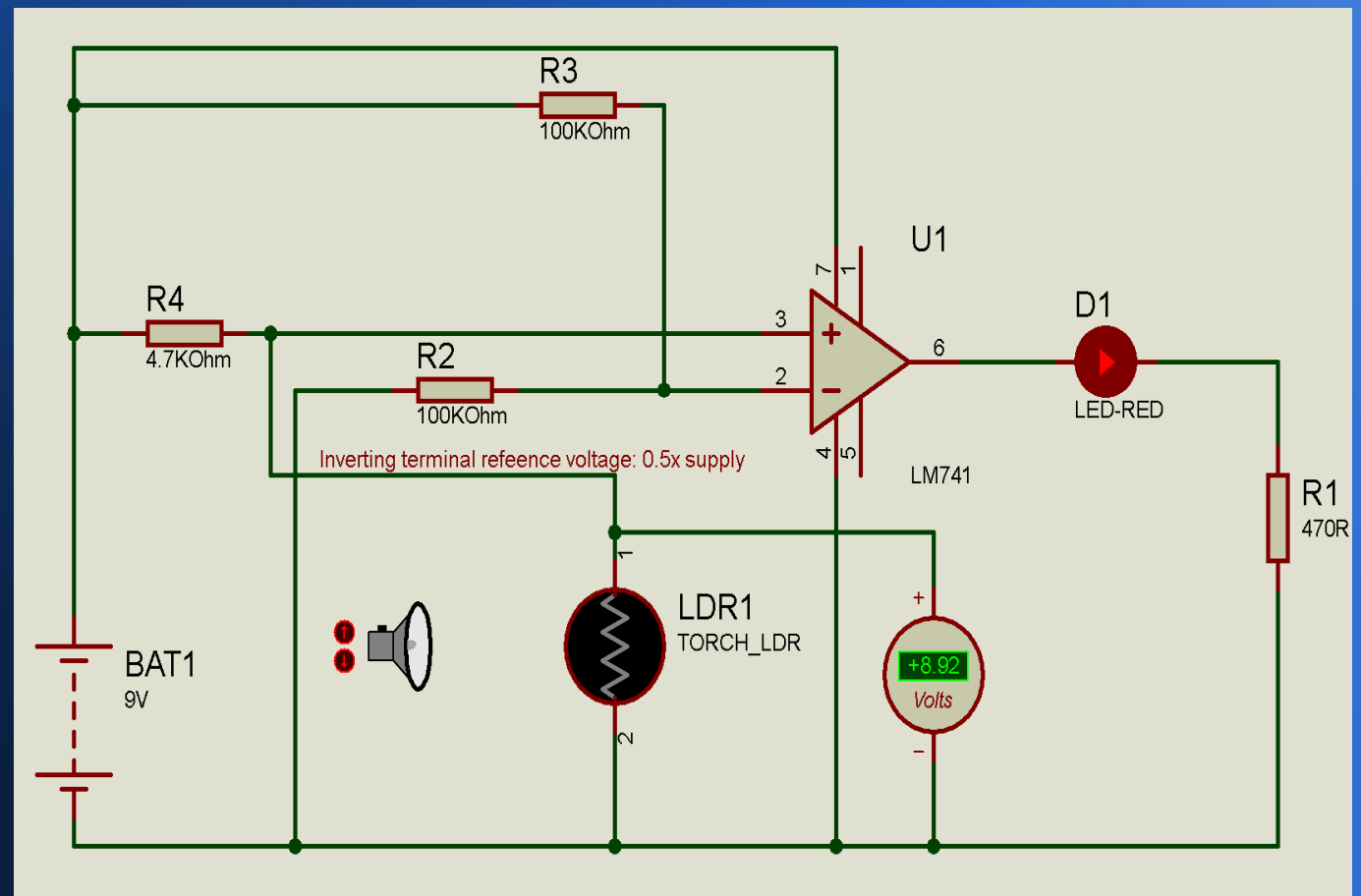

Sensing – Daytime (torch on) – note D1 light emitting diode is OFF.

Once light level increases, the voltage below the reference value of 4.5v, D1 turns off.

An easy way to automate illumination.

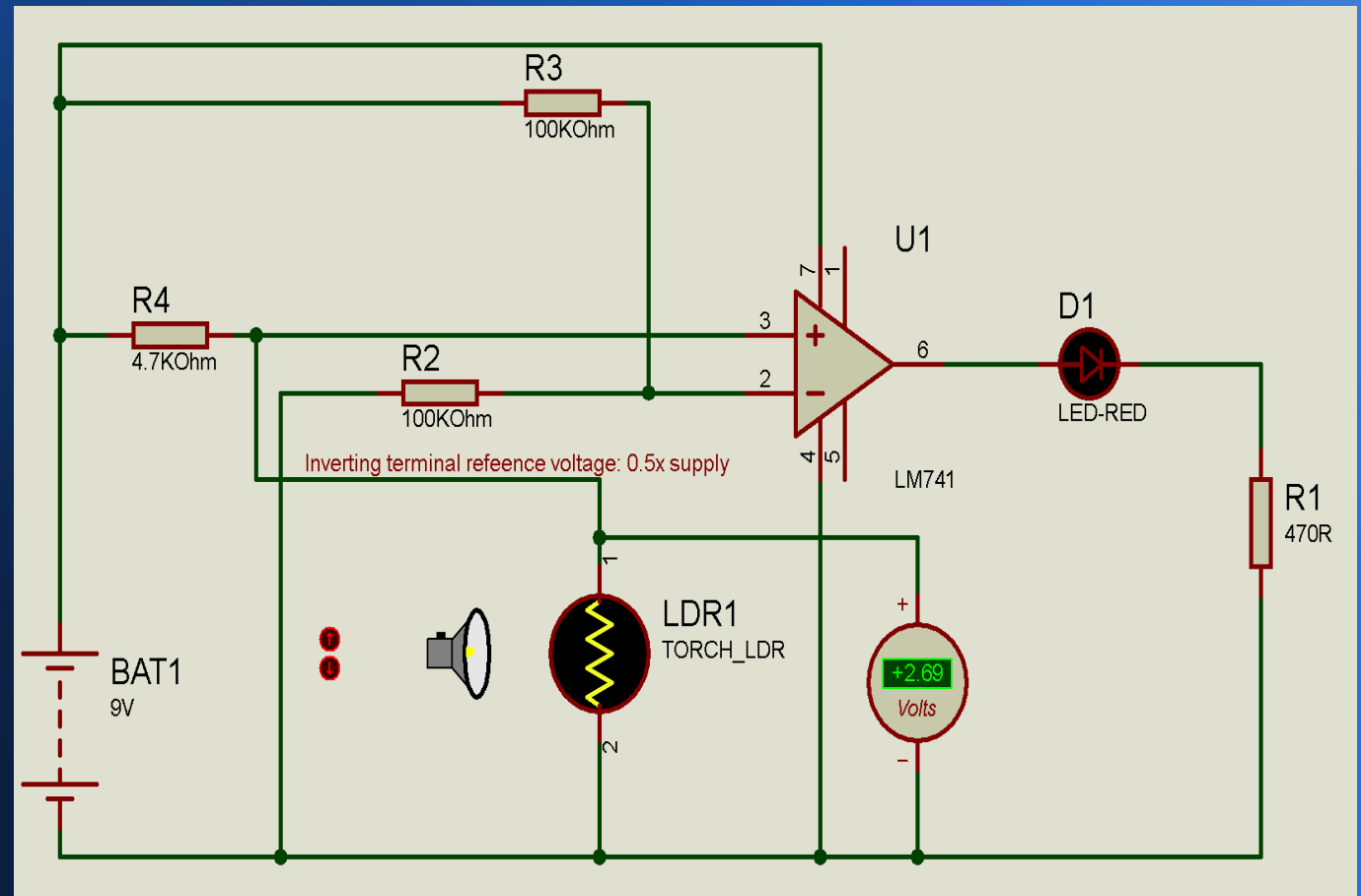

Sensing beyond human senses

- It is possible to design electronic devices which can sense things which we cannot sense directly. For a few examples:
- Ultrasound allows us to 'see' inside our bodies;
- Infrared camera images allow us to 'see' pictures of radiated heat;
- terahertz (micrometric) images allow us to see through opaque materials
- Our eyes are only sensitive to a tiny 'window' in the electromagnetic spectrum....

Sensing beyond human senses

- It is possible to design electronic devices which can sense things which we cannot sense directly. For a few examples:
- Ultrasound allows us to 'see' inside our bodies;
- Infrared camera images allow us to 'see' pictures of radiated heat;
- terahertz (micrometric) images allow us to see through opaque materials
- Our eyes are only sensitive to a tiny 'window' in the electromagnetic spectrum....

The electromagnetic spectrum

- Our eyes sense only wavelengths from 0.4 – 0.7 μm .

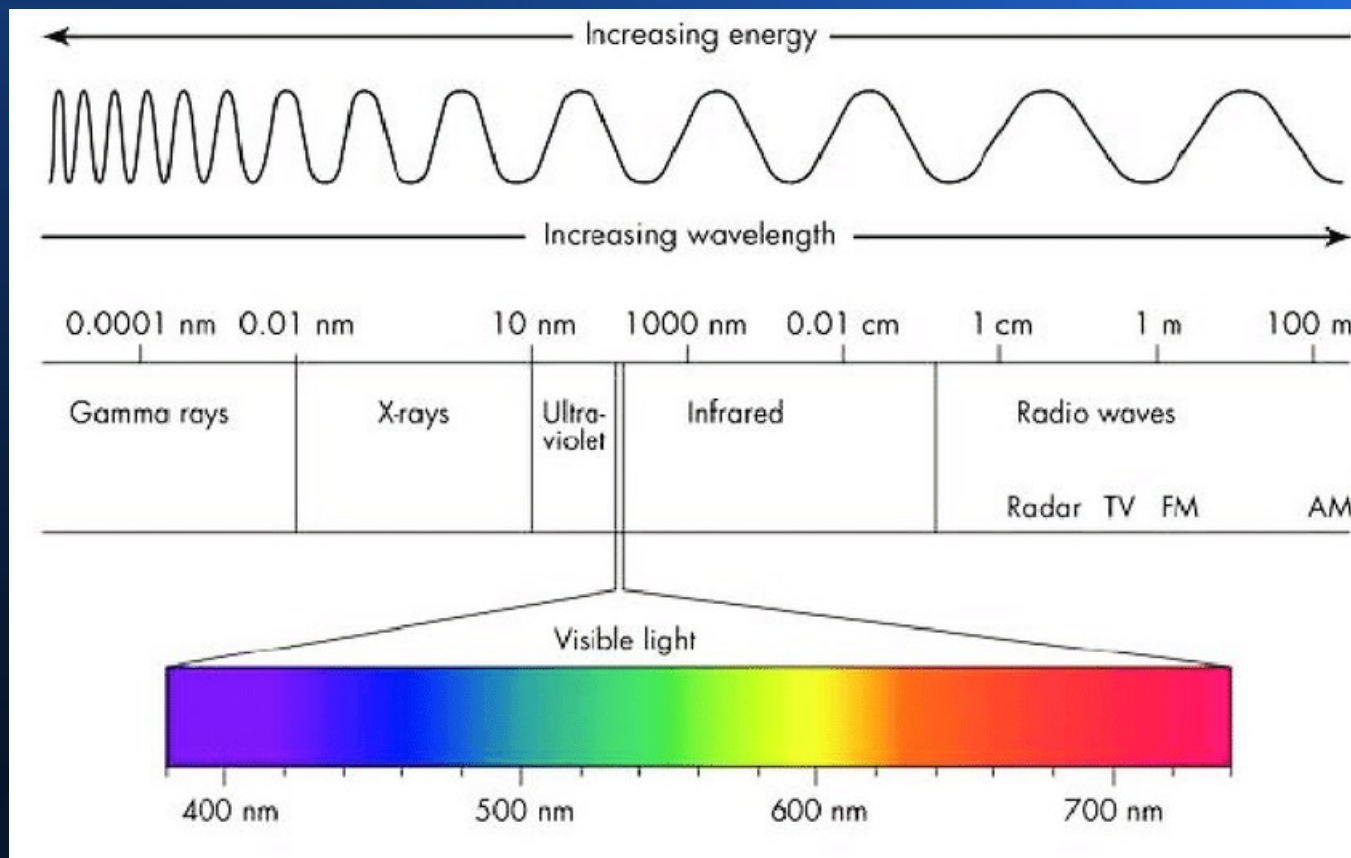

Logic – what is it?

- Sometimes the information from sensors is fed directly to a human being to act on, as in a visual display. However, in many cases that information is used to control systems automatically. To do this requires the functions of logic, which are carried out by logic circuits or programmable microprocessors or microcontrollers.

Actuation

- Actuators are components that control the movement in an autonomous system. In many systems, actuators of various kinds are automatically controlled to give the desired behaviour. Examples include electric motors (including stepper motors), and pneumatic actuators.
- Robotics are possible through clever use of actuation!

Active and Passive Electronic Components

- Examples and Differences between active and passive electronic components:
- Active electronic components are those that can control the flow of electricity. Different types of common basic circuits generally have at least one active component.
- Some examples of active electronic components are transistors, vacuum tubes, and silicon-controlled rectifiers (SCRs).
- Passive electronic components are those that don't have the ability to control electric current by means of another electrical signal. Examples of passive electronic components are capacitors, resistors, inductors, transformers, and some diodes.

List of Active Electronic Components

- Transistors, Diodes (All), Rectifier Diodes, Schottky Diodes
- Zener Diodes, Unipolar / Bipolar Diodes, Varicaps, Varactors
- Light-Emitting Diode (LED), Solar PV Cell, PV Panel
- Transistors (All), Photo Transistors, Darlington Transistors
- Compound Transistors, Field-Effect Transistors (FET).
- JFET (Junction Field-Effect Transistor)
- MOSFET (Metal Oxide Semiconductor FET)
- Thyristors
- Composit Transistors

List of Passive Electronic Components

- Resistors (All Types), Capacitors (All Types), Inductors / Coils
- Memristor / Networks, Sensors, Detectors, Transducers
- Antennas, Assembly Modules, Piezoelectric devices, Crystals
- Resonators, Terminals and Connectors, Cables, Switches
- Circuit Protection Devices (Such as fuses, earth leakage & other breakers)
- PCB's (The printed circuit board into which component are mounted);
- Mechanical Devices such as a Fan, Lamp or Motor
- The above conduct as a function of a simple mathematical relationship.

Ideal and real world components: some basic differences

- Only real devices can be measured, and only ideal elements can be calculated or simulated! An equivalent electrical circuit model is an idealised electrical description of a real structure.
- This is why real world results may not agree with those from a circuit simulation package such as Proteus (my usual choice nowadays), Pspice, Electronics Workbench (used at university and since graduation).
- And as we will see, random and systematic errors can give misleading results in laboratory work – as addressed in this course!
- Even equipment used for measurements is not 'ideal' – for example, an ideal voltmeter would have an infinite resistance; an ideal ampmeter would have zero resistance. And in the real world, measuring equipment can be affected by factors such as the temperature in the laboratory!

Real circuits vs. simulated circuits: real components (R, L, C) vs. ideal components

- As a graduate and an experienced engineer, and a radio amateur licenced since 1995, I can speak from experience here.
- This course is an introductory course. So I will only give a basic outline here regarding the differences between ideal and 'real world' components.
- Once you gain experience, you come to a realisation that throughout what you have been taught about electronic components and circuit schematics as a beginner, there is a hidden side that is rarely talked about and not ever discussed in detail.
- There is a lot of difference between the ideal schematic that shows the intended current flow with ideal components that follow the rules, and where the connecting wires have no resistance, capacitance and inductance, and what we have to deal with in practice...

Difference between theory & practice

- The real world is completely different to a simulation. The 'hidden aspects' in a practical circuit tend to manifest themselves most at high frequencies.
- Resistors have frequency responses, capacitors have inductances, and inductors have resistances; PCB tracks have inductances and also capacitances between them.
- As an experienced radio amateur and circuit designer, I am well aware that for example, a voltage controlled oscillator performs fairly adequately at HF frequencies (3-30MHz) if well designed, but is quite simply too unstable at VHF (30-300MHz), let alone UHF (300MHz – 3GHz)!
- Here are some brief examples of why the real world differs from the ideal. The list is NOT exhaustive.

Factors which cause circuit behaviour to deviate from a simulation

- As mentioned previously, even straight wires generate a magnetic field – hence they have inductance
- All conducting materials have some resistance, with the exception of a true superconductor very close to absolute zero (-273.16°C , 0°K)
- A wire wound resistor is a coil of wire – this is how an inductor is made, after all! Indeed all inductors, including the windings of motors and transformers, possess some resistance.
- Capacitor plates are separated by an insulating gap – the dielectric. In practice the insulating material is not perfect! Capacitors, eventually, lose charge through their own shunt resistance, and a high enough voltage will ionize the air between and arc – spark! Across the gap!
- Spaces between wires act as a stray capacitor – hence 'stray capacitance'.

Factors which cause circuit behaviour to deviate from a simulation

- Capacitors made of a coil of aluminium foil with a dielectric separator in a 'swiss roll' arrangement possess inductance as well as the intended capacitance. As will manifest itself at higher frequencies!
- Transformers have loss due to ohmic resistance in the windings, stray 'eddy' current in the core, capacitance between the primary and secondary coils
- Resistors (and in particular semiconductors) have a temperature co-efficient
- Even diodes have stray capacitance – as do transistor junctions
- And measured values can at best be only as good as the measurement technique employed!

Periodic Table of the elements

(For reference, Silicon and Germanium are Metalloids).

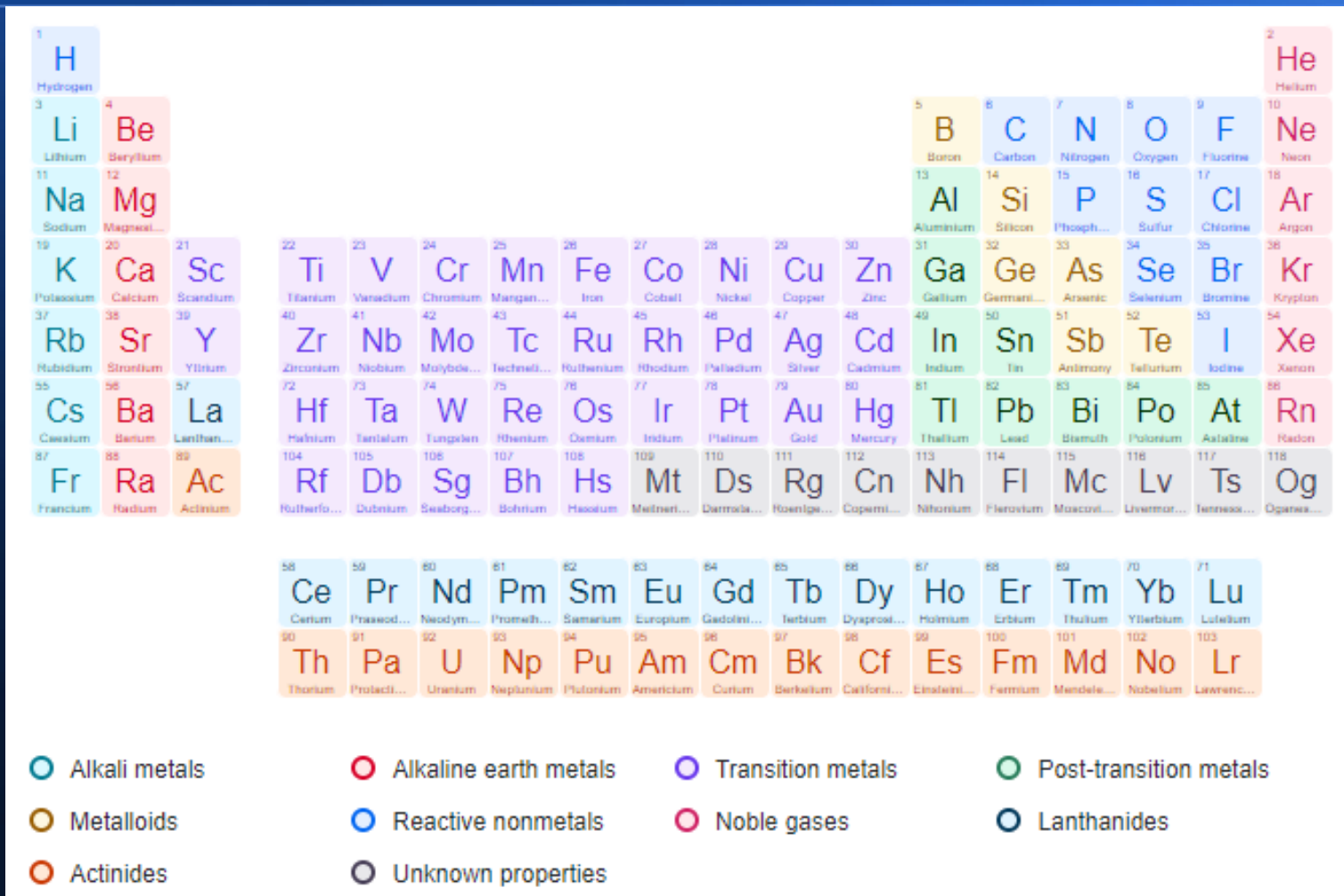

How to Create a linearised Logarithmic Graph and equation

- How to Write the equation of a Linear Function whose Graph has a Line that is non linear – and to plot it in a linear form
- Many functions have a non-linear graph and equation.
- So -how to Write the equation of a Linear Function whose Graph has a Line with a straight gradient, and express the graph in linear form:
- Many functions have a non-linear relationship. Examples include: $y = x^2$, $y = \ln(x)$, $y = \log_{\text{base } n}(x)$, $y = e^x$, $y = 1/x$.
- A linear/log graph, formally known as a semi-logarithmic graph, is a graph that uses a linear scale on one axis and a logarithmic scale on the other axis. It's useful in science for plotting data points of two variables where one of the variables has a much larger range of values than the other variable. By plotting the data in this way, we can frequently observe relationships in the data that would not be as obvious if both variables were plotted linearly.

How to Create a Logarithmic Graph and equation

- Let us use the example of $y = \log_{10}(x)$. This is entered in Derive as $y = \log(x, 10) x$.
- The problem here is that relationships which would be obvious on a linear graph – of linear gradient – are hidden here.
- Also, many quantities which you encounter in engineering give very wide ranges of values. An example of such a quantity is sound intensity. Our ears detect sound logarithmically – a sound you perceive as twice as loud may actually have a change in amplitude of a factor of ten.
- Similarly, our eyes are also logarithmic in terms of light intensity. This is because they need to avoid damage in bright sunlight, but become very sensitive at night (they also sacrifice colour vision to improve sensitivity – which is why you only see in monochrome in the dark).

Let us use $y = \log_{10}(x)$ as an example.

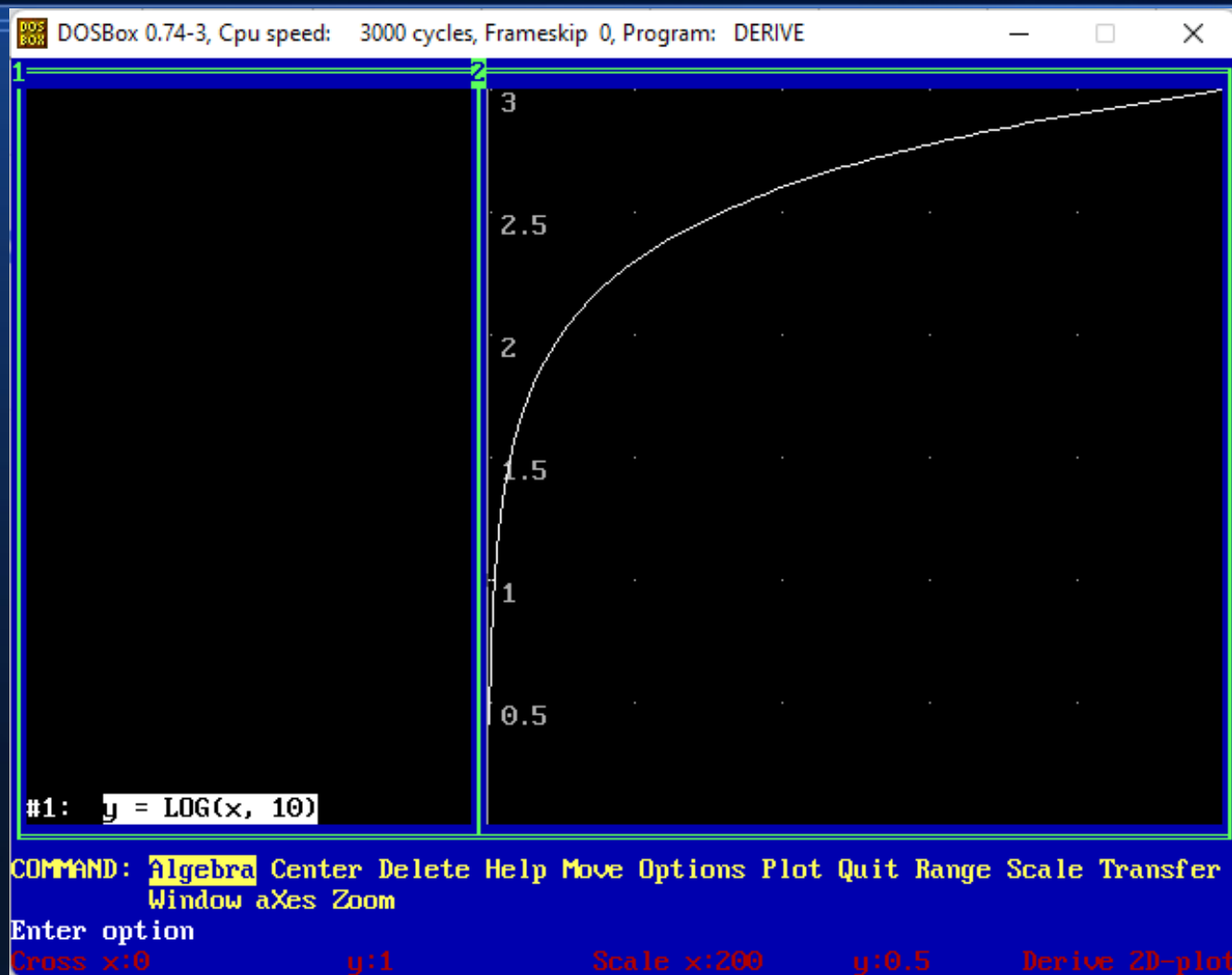

Let us view this on different scales...

- The range of the graph is shown at the bottom.
- Here x range is 0-10.



Let us view this on different scales...

- Here x range is 0 to 10^6 (on million).

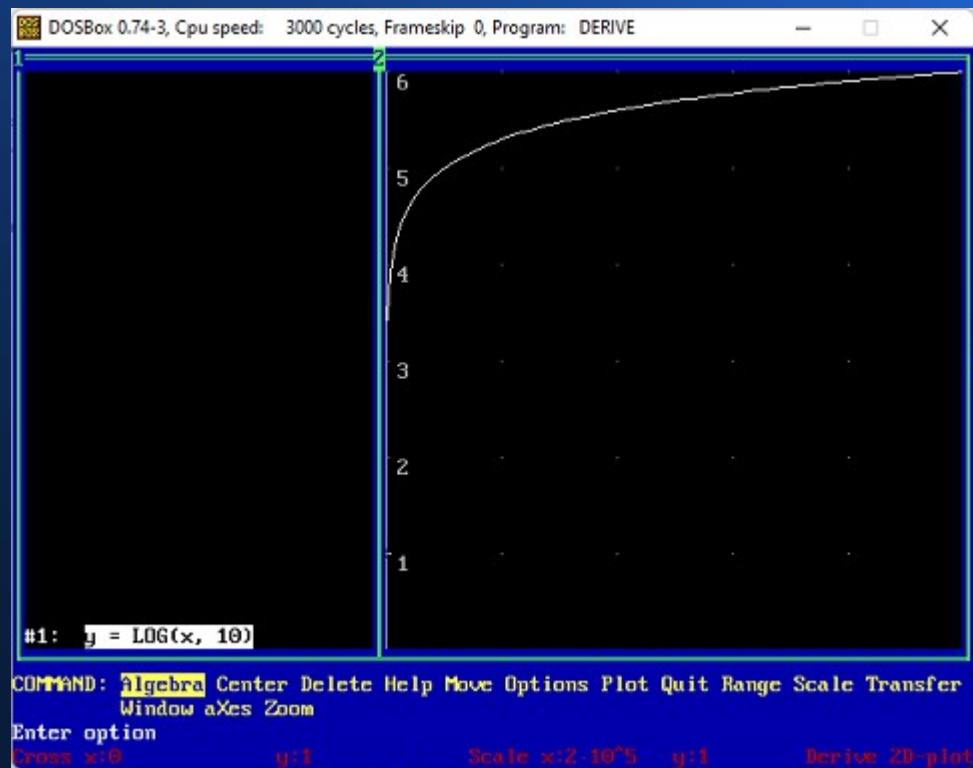

Let us view this on different scales...

- And remember, $y = \log_{10}(x)$ – indeed all logarithmic graphs, start at – where
- $Y = 0$. So, how can we linearise the graph? Well, here comes the trick...

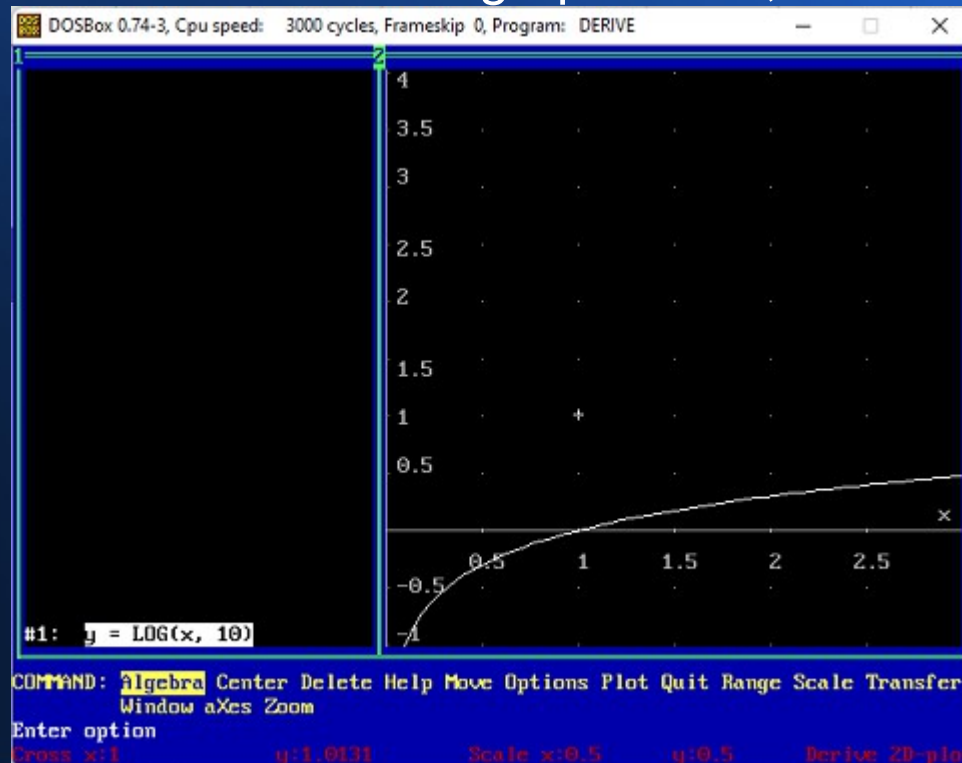

How to Create a linearised Logarithmic Graph and equation

- A log graph, formally known as a semi-logarithmic graph, is a graph that uses a linear scale on one axis and a logarithmic scale on the other axis. It's useful in science for plotting data points of two variables where one of the variables has a much larger range of values than the other variable. By plotting the data in this way, we can frequently observe relationships in the data that would not be as obvious if both variables were plotted linearly.
- It also has the advantage of allowing very wide ranges to actually fit onto a graph!

How to Create a linearised Logarithmic Graph and equation?

- Use a lin-log graph. This type of log graph has a y axis with a linear scale and an x axis with logarithmic scale. The scale of the x axis is therefore compressed by a factor of 10^x in relation to the y axis. In the illustration, $y = 10^x$ on the linear graph. $Y = 10^x$ in red intersects the y axis at $x = 10$ and has a positive slope that approaches infinity. $Y = x$ in green now looks like $y = 10^x$ on the linear graph.
 - This is known as a semi-logarithmic graph – it is linear on one axis and logarithmic on the other.

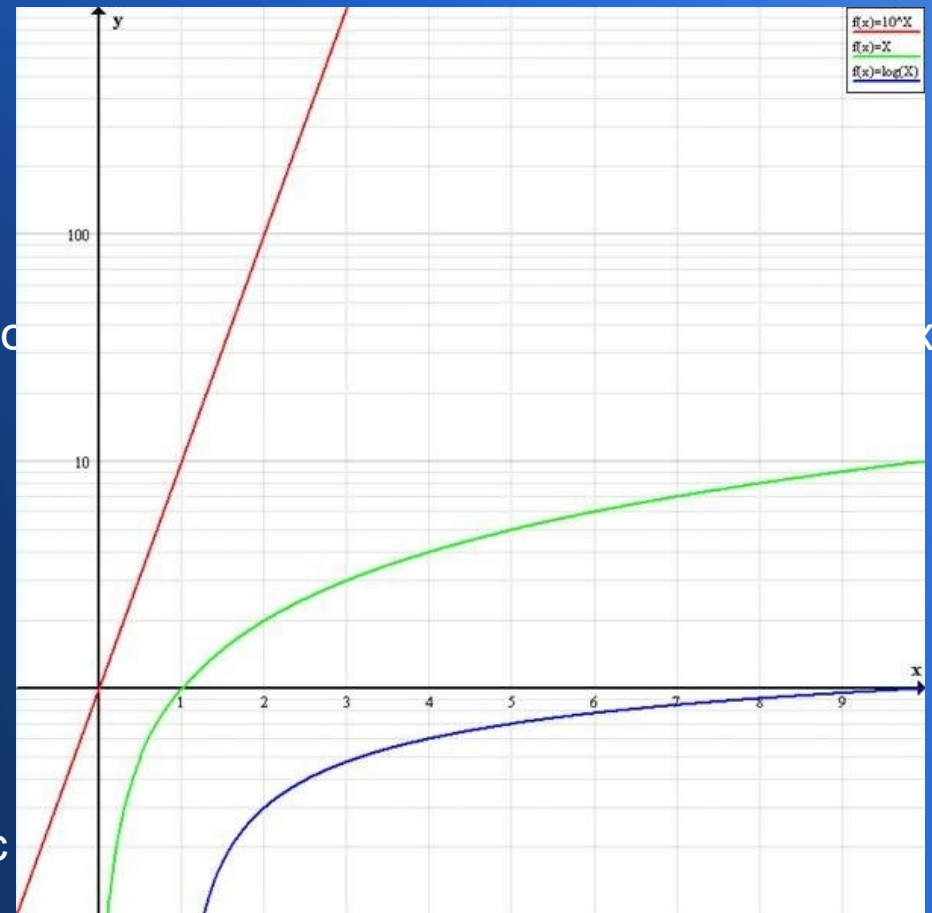

How to Create a linearised Logarithmic Graph and equation

- Examples of graphs which you might want to Linearise are here. The table on the next page shows how to plot them.

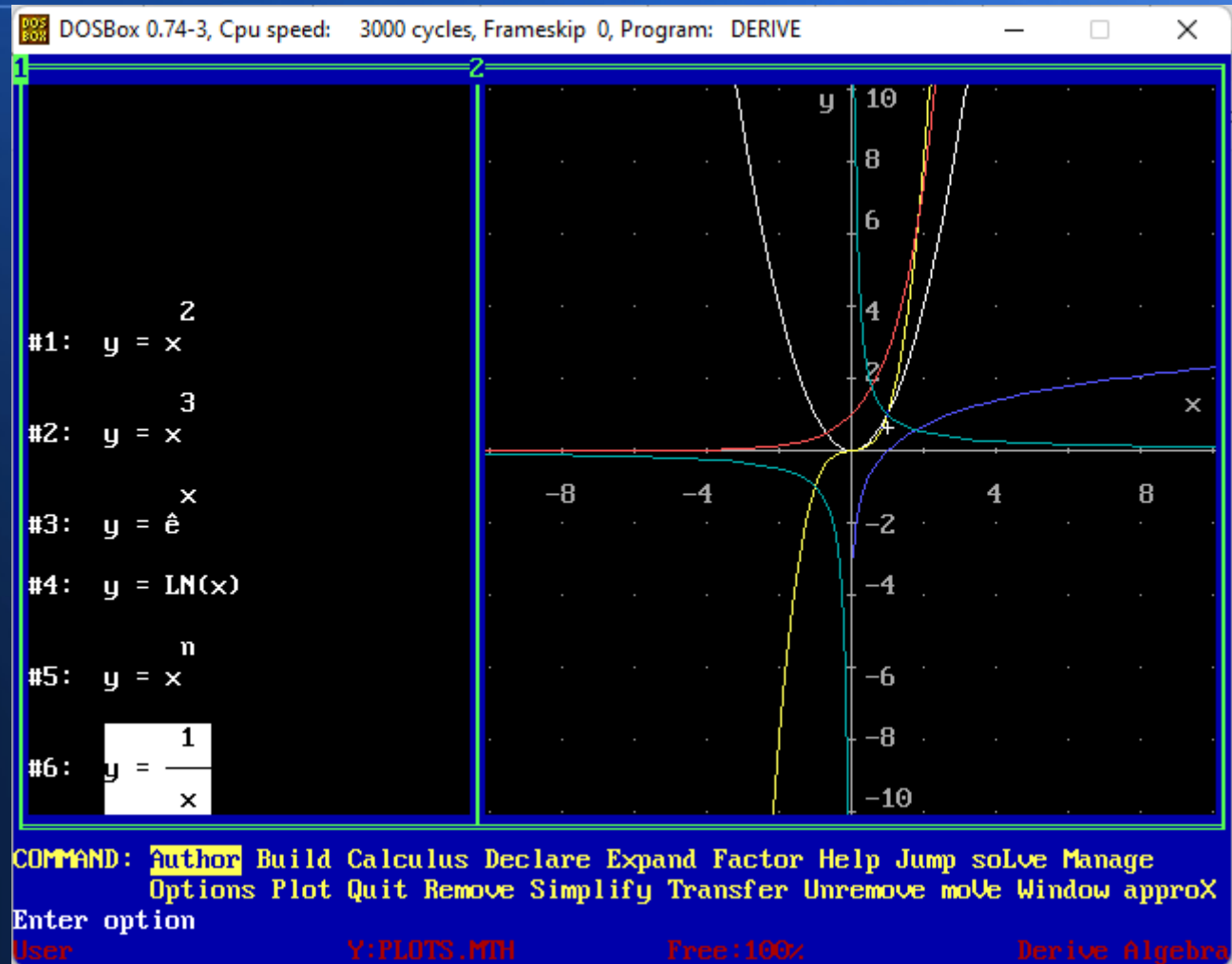

How to linearise these examples...

Expression	Linear plot – x axis	Linear plot - y axis
$Y = x^2$	x^2	Y
$Y = x^3$	x^3	y
$Y = e^x$ (Exponential)	e^x	y
$Y = \ln(x)$ (Natural logarithm)	$\ln(x)$	y
$Y = x^n$	x^n (if n value is known)	y
$Y = 1/x$ (reciprocal).	$1/x$	y

Using a Log-Log Graph

- Occasionally, both values required have too wide a range to show on a linear graph. In this case, we can use a log/log graph so the scale of both axes is logarithmic.
- For example, here is a graph of $y=100x^2$ for x values from 1 to 100000, 10^5 .

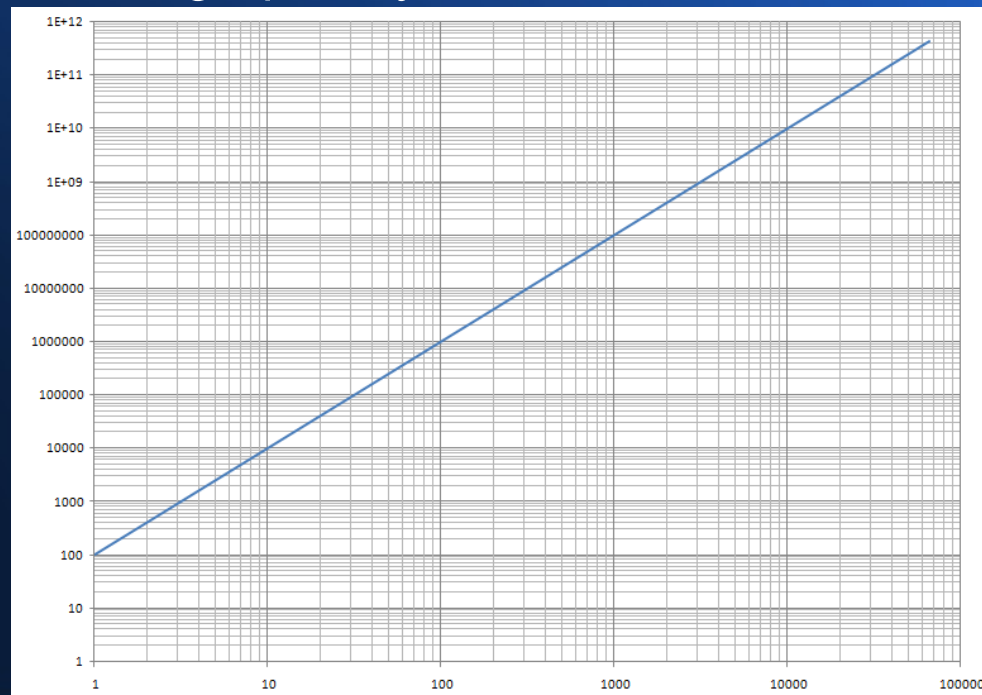

Using a Log-Log Graph: Notice how the plot is divided evenly into "blocks" by powers of ten. This allows a flat gradient to be visible on the graph. You can now easily see the relationship between the values.

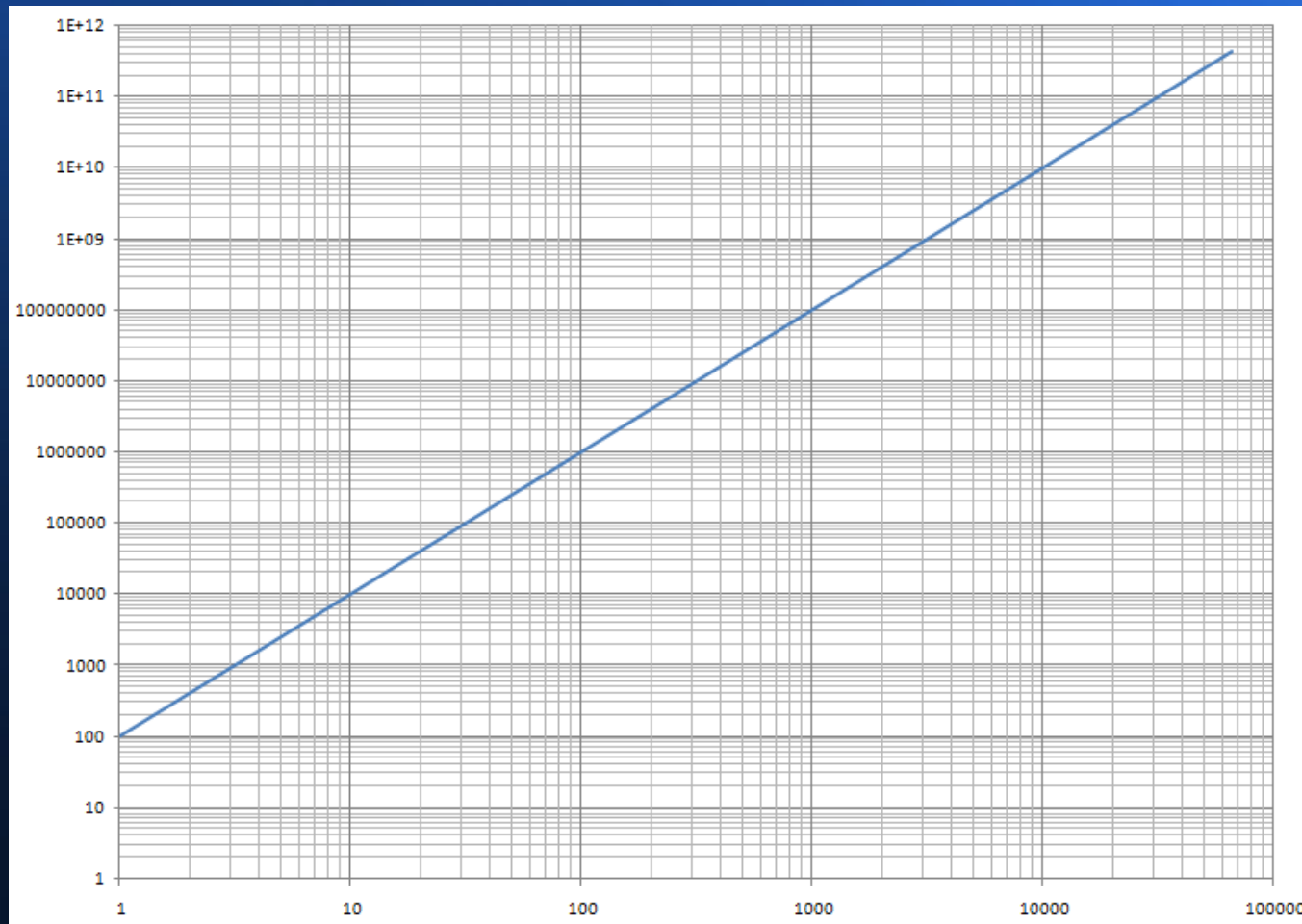

In Microsoft Excel, how can I make a log or log-log graph?

- To create a log-log graph in Microsoft Excel, you must first create an XY (scatter) graph. This is the only graph type that will work; other graph types permit logarithmic scales only on the Y axis. To create a log-log graph, follow the steps below for your version of Excel.
- For Excel 2010 or 2007:
 - In your XY (scatter) graph, right-click the scale of each axis and select Format axis....
 - In the Format Axis box, select the Axis Options tab, and then check Logarithmic scale.
- For older versions of Excel:
 - In your XY (scatter) graph, double-click the scale of each axis.
 - In the Format Axis box, select the Scale tab, and then check Logarithmic scale.
- I have not tried it in newer versions of Excel.

Linearising an Equation

- In mathematics, linearisation is finding the linear approximation to a function at a given point. The linear approximation of a function is the first order Taylor expansion around the point of interest. In the study of dynamical systems, linearisation is a method for assessing the local stability of an equilibrium point of a system of nonlinear differential equations or discrete dynamical systems.
- Linearisations of a function are simply straight lines—usually lines that can be used for purposes of calculation. Linearisation is an effective method for approximating the output of a function at any given point based on the value and slope of the function at this point. In essence, linearisation approximates the output of a function very close to a given value.
- Please be aware that this will only be of reasonable accuracy over a narrow range of X values.

Linearising an Equation

- Because differentiable functions are only vary locally linear, the best slope to substitute in would be the slope of the line tangent to $f(x)$ at $x = a$.
- For example, if $f(x) = x^2$ then drawing a tangent line to the graph will provide an approximation of the gradient for very narrow ranges of $f(x)$ only.

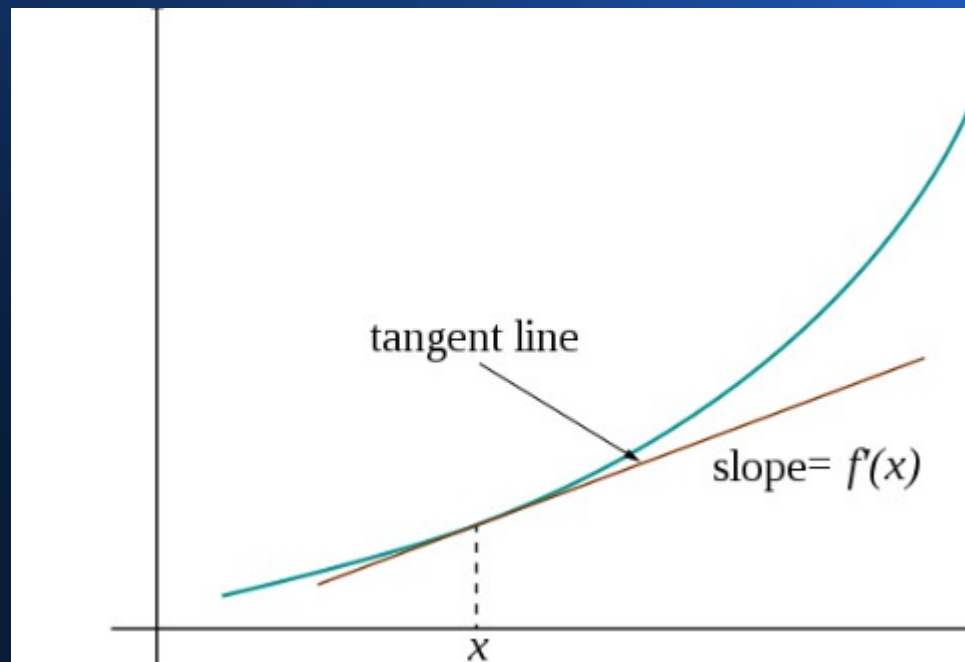

Linearising an Equation

- The only way to find a general linearisation for a function is to find its derivative. For example, the derivative of $y = 3x^3$ is $9x^2$.

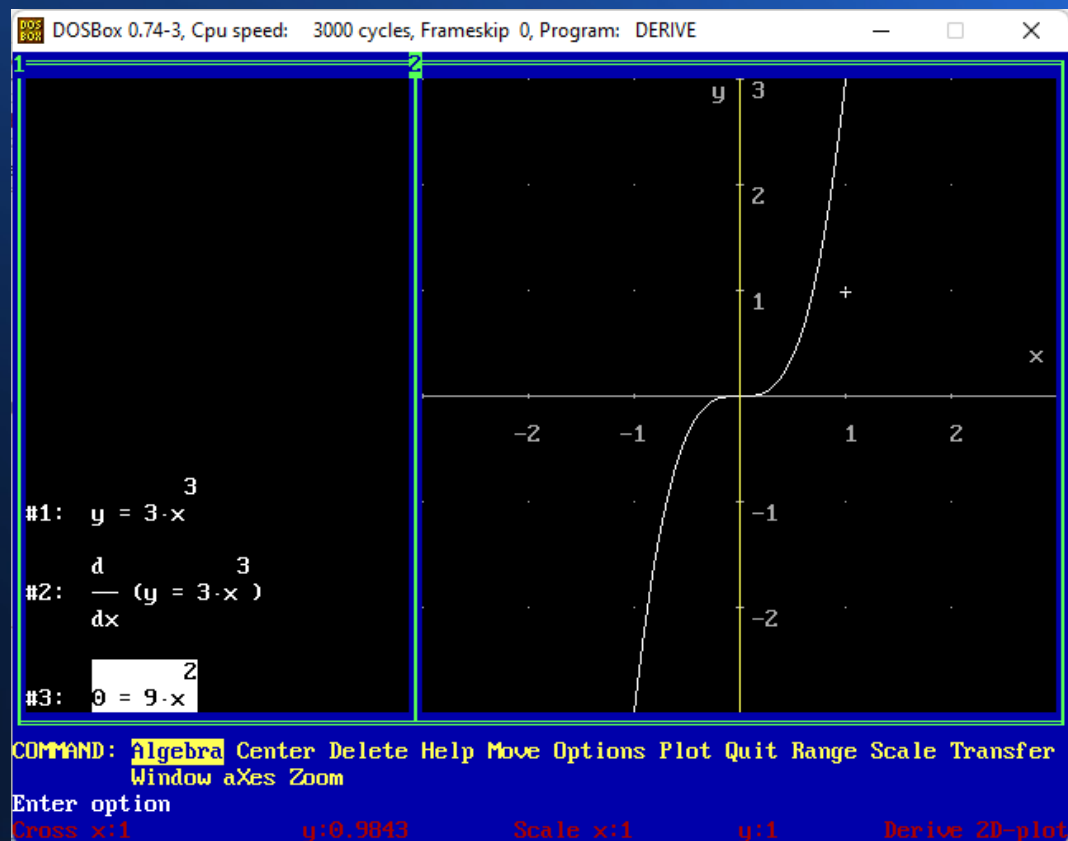

Examples of common derivatives

- Please note that these are common derivatives. These find the general case of the gradient of a function for a very narrow range of $f(x)$, drawing a tangent is an approximation.

$$\frac{d}{dx}(a) = 0$$

$$\frac{d}{dx}(x) = 1$$

$$\frac{d}{dx}(au) = a \frac{du}{dx}$$

$$\frac{d}{dx}(u + v - w) = \frac{du}{dx} + \frac{dv}{dx} - \frac{dw}{dx}$$

$$\frac{d}{dx}(uv) = u \frac{dv}{dx} + v \frac{du}{dx}$$

$$\frac{d}{dx}\left(\frac{u}{v}\right) = \frac{1}{v} \frac{du}{dx} - \frac{u}{v^2} \frac{dv}{dx}$$

$$\frac{d}{dx}(u^n) = nu^{n-1} \frac{du}{dx}$$

$$\frac{d}{dx}(\sqrt[n]{u}) = \frac{1}{2\sqrt[n]{u}} \frac{du}{dx}$$

$$\frac{d}{dx}\left(\frac{1}{u}\right) = -\frac{1}{u^2} \frac{du}{dx}$$

$$\frac{d}{dx}\left(\frac{1}{u^n}\right) = -\frac{n}{u^{n+1}} \frac{du}{dx}$$

$$\frac{d}{dx}[f(u)] = \frac{d}{du}[f(u)] \frac{du}{dx}$$

$$\frac{d}{dx}(\ln u) = \frac{d}{dx}[\log_e u] = \frac{1}{u} \frac{du}{dx}$$

$$\frac{d}{dx}[\log_a u] = \log_a e \frac{1}{u} \frac{du}{dx}$$

$$\frac{d}{dx}e^u = e^u \frac{du}{dx}$$

$$\frac{d}{dx}a^u = a^u \ln a \frac{du}{dx}$$

$$\frac{d}{dx}(u^v) = vu^{v-1} \frac{du}{dx} + \ln u \cdot u^v \frac{dv}{dx}$$

$$\frac{d}{dx} \sin u = \cos u \frac{du}{dx}$$

$$\frac{d}{dx} \cos u = -\sin u \frac{du}{dx}$$

$$\frac{d}{dx} \tan u = \sec^2 u \frac{du}{dx}$$

$$\frac{d}{dx} \cot u = -\csc^2 u \frac{du}{dx}$$

$$\frac{d}{dx} \sec u = \sec u \tan u \frac{du}{dx}$$

$$\frac{d}{dx} \csc u = -\csc u \cot u \frac{du}{dx}$$

Errors and Uncertainties

- The difference between uncertainty and error:
- The main difference between errors and uncertainties is that an error is the difference between the actual value and the measured value, while an uncertainty is an estimate of the range between them, representing the reliability of the measurement. In this case, the absolute uncertainty will be the difference between the larger value and the smaller one.
- A simple example is the value of a constant. Let's say we measure the resistance of a material. The measured values will never be the same because the resistance measurements vary. We know there is an accepted value of 3.4 ohms, and by measuring the resistance twice, we obtain the results 3.35 and 3.41 ohms.
- Errors produced the values of 3.35 and 3.41, while the range between 3.35 to 3.41 is the uncertainty range.

Errors and Uncertainties

- What is the standard error in the mean?
- The standard error in the mean is the value that tells us how much error we have in our measurements against the mean value. To do this, we need to take the following steps:
- Calculate the mean of all measurements.
- Subtract the mean from each measured value and square the results.
- Add up all subtracted values.
- Divide the result by the $\sqrt{}$ of the total number of measurements taken.

Errors and Uncertainties

- PRECISION AND ACCURACY:
- Accuracy is the closeness of agreement between a measured value and a true or accepted value (measurement error reveals the amount of inaccuracy).
- Precision is a measure of the degree of consistency and agreement among independent measurements of the same quantity (also the reliability or reproducibility of the result).
- A voltmeter which gives readings of 10, 10, 10, 10 and 10 volts on five measurements of a known voltage of 10 volts is both precise and accurate;
- A meter registering 8,8,8,8, and 8 volts on five measurements at a known voltage of 10 volts is precise, but not accurate
- A meter which reads 11, 10, 8, 9 and 12 volts on five measurements of a known source of 10 volts is neither precise nor accurate.

Errors and Uncertainties

- For example, think of playing darts:

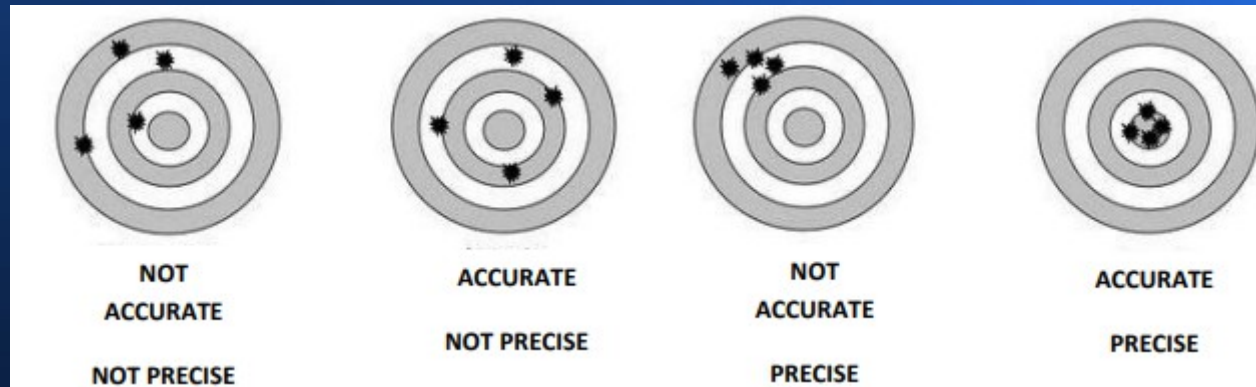

Errors and Uncertainties

- RANDOM AND SYSTEMATIC ERRORS

- There are 2 types of errors in measured data. It is important to understand which you are dealing with, and how to handle them.
- **RANDOM ERRORS** refer to random fluctuations in the measured data due to:
 - The readability of the instrument
 - The effects of something changing in the surroundings between measurements
 - The observer being less than perfect (yes that's you!)
- Random errors can be reduced by averaging. A precise experiment has small random error.
- **SYSTEMATIC ERRORS** refer to reproducible fluctuations consistently in the same direction due to:
 - An instrument being wrongly calibrated
 - An instrument with zero error (it does not read zero when it should – to correct for this, the value should be subtracted from every reading)
 - The observer being less than perfect in the same way during each measurement. Ξ
- Systematic errors cannot be detected or reduced by taking more measurements. Even an accurate experiment has small systematic error.
- When graphing experimental data, you can see immediately if you are dealing with random or systematic errors (if you can compare with theoretical or expected results).

Errors and Uncertainties

- REPORTING A SINGLE MEASUREMENT
- You would be surprised at how few people actually know how to take a proper reading of something!
- Most people try to report a measured value with a degree of certainty that is too generous – expressing more certainty in a reported value than really exists. You should avoid this! It is bad practice.
- Generally we report the measured value of something with the decimal place or precision going not beyond the smallest graduation (called the ‘least count’) on the instrument. In cases where the least counts are wide enough to estimate beyond them with certainty, you may do so. It is ultimately up to the experimenter to determine how to report a measured value, but be conservative and do not overestimate the precision of the instrument.
- Sometimes you hear that uncertainties should generally be reported as $\frac{1}{2}$ the least count; this is technically correct. But since they should be reported with the same number of decimal places as the instrument, in practice this amounts to stating them as \pm the least count.

Errors and Uncertainties

- REPORTING YOUR BEST ESTIMATE OF A MEASUREMENT
- The best way to come up with a good measurement of something is to take several measurements and average them all together. Each individual measurement has uncertainty, but the reported uncertainty in your average value is different than the uncertainty in your instrument. You do not use the instrument uncertainty in your final stated uncertainty – the precision of the instrument is not the same as the uncertainty in the measurement.
- If you take several measurements of something, you will get a range of values. The ‘real’ value should be within this range, and the uncertainty is determined by dividing the range of values by two. Always round your stated uncertainty up to match the number of decimal places of your measurement, if necessary.
- Your stated uncertainty should have only one significant figure if possible. In a physics laboratory, you should take 3 to 5 measurements of everything. Five is always best if you can manage it!

Errors and Uncertainties

- As an example:
- Six students measure the resistance of a lamp. Their answers in Ω are: 609; 666; 639; 661; 654; 628. What should the students reports as the resistance of the lamp?
- Average resistance = 643Ω
- Largest - smallest resistance $666 - 609 = 57 \Omega$
- Dividing the range by 2 = 29Ω
- So, the resistance of the lamp should be reported as: $643 \pm 30 \Omega$

Errors and Uncertainties

- When taking several measurements, it should be clear if you have a value with a large error. Do not be afraid to discard any measurement that is clearly a mistake. You should never be penalised for this if you explain your rationale for doing so. In fact, it is permissible, if you have many measurements, to throw out the maximum and minimum values.
- When taking time measurements, the stated uncertainty cannot be unreasonably small – I would definitely say not smaller than 0.3 s, no matter what the range. When taking time measurements (such as the period of a pendulum), we can improve the accuracy of our data by measuring the time taken for 20 oscillations for example ($20T$). In this case, you can divide the uncertainty for $20T$ by 20 to get the uncertainty in T .
- For a pendulum, 20 oscillations ($20T$) are timed (in seconds) at 14.73; 14.69; 14.75 . What is T ? The range in values is 0.06, but you cannot report the value for $20T$ as 14.72 ± 0.03 s. You must report it as 14.72 ± 0.30 s but $T = 0.7360 \pm 0.0150$ s or better stated as $T = 0.7360 \pm 0.0200$ s.

Errors and Uncertainties

- Uncertainty in calculated results: absolute and percentage uncertainties
- Absolute uncertainties are expressed as \pm the number of units in the measurement ($\pm \Delta x$).
- Length = 234 ± 2 mm Period = 1.6 ± 0.3 s
- This tells you immediately the maximum and minimum experimental values of a measurement.
- Absolute uncertainties have the same units as the stated measurement. All uncertainties begin as an absolute uncertainty, stated according to the uncertainty in the precision of the instrument.
- Percentage uncertainties are expressed as \pm [the fractional uncertainty in the measurement $\times 100$] ($\pm [(\Delta x/x)100]\%$).
- Length = 234 ± 2 mm or $234 \pm (2/234)\times 100 = 234 (\pm 8.5 \%)$ mm
- Period = 1.6 ± 0.3 s or $1.6 \pm (0.3/1.6)\times 100 = 1.6 (\pm 18.8 \%)$ mm
- Percentage uncertainties are unitless and can save lots of time when making calculations, even though it seems cumbersome to express uncertainty this way.

Errors and Uncertainties

- It is good form to leave all final calculated answers with an absolute uncertainty. Therefore, you need to be able to convert from absolute uncertainties to percentage and back again. Constants such as π do not affect the uncertainty calculation.
- When doing calculations involving percentage uncertainties, it is easier to leave out the ($\times 100$) step and simply multiply using the decimal form.
- Uncertainties when making graphs:
- In many cases, the best way to present and analyse data is to make a graph. A graph is a visual representation of 2 things and shows nicely how they are related. A graph is the visual display of quantitative information and allows us to recognise trends in data. Graphs also let you display uncertainties nicely.

Errors and Uncertainties

- Making Graphs – please note
- You need to be able to make graphs by hand in the laboratory (**and always on graph paper please!**), even though in many cases in the writing up you will be using computer software to create graphs using spreadsheets of data.
- It is generally best where possible to use specialist software for graphing purposes. Excel, for example, produces graphs which are of adequate accuracy for business use (for which it is chiefly intended) but it is not best suited to scientific use. For example, it may employ inadequate numerical or statistical techniques, its shortcomings may be poorly documented if at all, and in particular its plotting of logarithmic graphs leaves a lot to be desired (the points are not always the correct distance apart on a logarithmic scale).

Errors and Uncertainties

- Good practice when making graphs:
 1. The independent variable is on the x-axis and the dependent variable is on the y-axis.
 2. Every graph should have a title that is concise but descriptive, in the form 'Graph of (dependent variable) vs. (independent variable)'.
 3. The scales of the axes should suit the data ranges.
 4. The axes should be labeled with the variable, units, and uncertainties.
 5. Ample paper area should be used.
 6. The data points should be clear.
 7. Error bars should be shown correctly (using a straight-edge)
 8. Data points should not be connected dot-to-dot fashion. A line of best fit should be drawn instead.
 9. Each point that does not fit with the best fit line should be identified.
 10. Think about whether the origin should be included in your graph (what is the physical significance of that point?)

Errors and Uncertainties

- A nice way to show uncertainty in data is with error bars. These are bars in the x and y directions around each data point that show immediately how big or small the uncertainty is for that value. Uncertainties can be constant values for every data point or percentage values (in which case the length will vary).
- Either way, an error box is created when there are error bars in both x and y directions around a data point. It is usually a rectangle and often varies in size around every point.

Errors and Uncertainties

- The line of best fit (which can be a curve OR a straight line) represents the trend shown on a graph. If you are doing this by hand, it is an estimation based on what the trend appears to be. For example, the data might suggest a linear relationship – if so, your job is to draw a line (with a straightedge) that goes through as many data points as possible.
- Approximately the same number of data points should be above your line as below it. That said, I would automatically be suspicious of every data point lay neatly on the line of best fit.

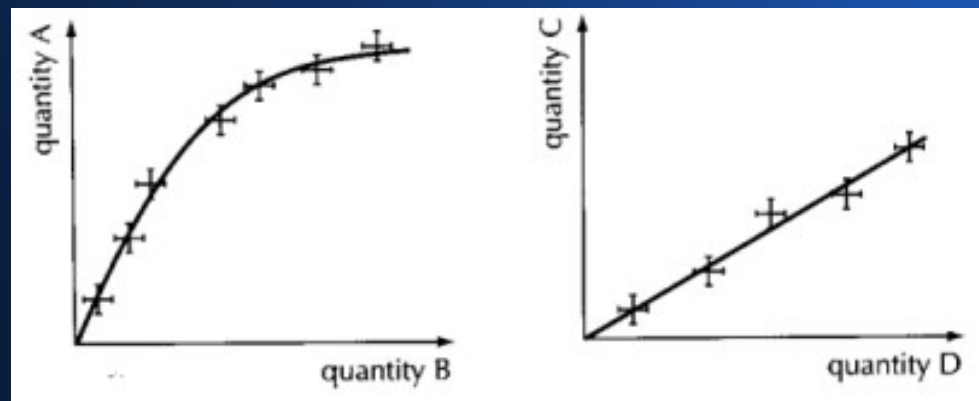

Exam Revision Techniques

- Take some time to understand your learning style
- When it comes to finding the best revision techniques for students, it all begins with understanding how you learn best, e.g. what your learning style is. There are lots of different learning styles out there, with many turning to the VARK theory to understand their preferred learning style. In essence, the VARK theory identifies us as being one of the following learners: visual, aural, read (or write), or kinaesthetic – take the test below to find out which type of student you are!
- Once you know the method of learning that suits you best, simply tailor each of your revision sessions by choosing the techniques that will make remembering the information much easier for you. You'll find that your revision becomes far easier, engaging, and effective on the whole.
- <https://vark-learn.com/the-vark-questionnaire/>

Exam Revision Techniques

- Organise your notes ahead of time
- To ensure you can kick-start your revision in the most efficient way possible, it's a good idea to (if they aren't already) organise, label, and clearly order your subject notes so that they are easy to read through and use as part of the revision process.
- When you sit down on your first few days of revision, the last thing you want to have to do is waste time finding and filing all your class notes together for you to then begin your revision. Taking the time outside of class to condense and organise your notes into a formulated system will have endless benefits, both at helping you to reconfirm your understanding of the content after class, but also making your revision far more manageable.

Exam Revision Techniques

- Use mind maps to connect ideas
- When it comes to your revision, do you find yourself struggling with remembering lots of new information? Or understanding how different topics relate to each other? Well, mind maps may be key to helping you succeed!
- In essence, the theory behind using mind maps is that making associations between related ideas can help us to memorise information quicker and faster – making it a very effective revision technique.
- Mind maps begin with one central theme or topic. From here, you can then create branches from this central idea with other related ideas that you want to develop or visualise. From these branches, you can add further detail and information, with keywords helping you to summarise information, include key terminology, and visually connect ideas between one another.
- Having a topic summarised into a mind map on one big sheet of A3 paper can be hugely beneficial to information retention, especially if you also use visual aids to help summarise processes or definitions.

Exam Revision Techniques

- Complete as many past papers as possible!
- Another highly effective revision technique to help you prepare for your exams is to get familiar with past papers. After all, there's no point learning all that content if you don't know how to apply it to the exams.
- Past papers can be great at helping you become familiar with the format of exams, including the different types of question styles and time restraints. Then, when it comes to the real thing, you'll know exactly what to expect.
- But aside from this, completing past papers can also be a good way to test your current understanding of a subject and identify any gaps of knowledge or areas that you're struggling with.

Exam Revision Techniques

- Lastly, mix your study habits up to keep it engaging
- For some ideas on how to keep your revision engaging, try using one or some of the following techniques:
- Watch video demonstrations or documentaries
- Listen to podcasts
- Organise a group study session
- Mix your study time between at-home and at a library or local café
- Write about your topic as if you were telling a story
- Try teaching a topic to a friend or family member who has little to no knowledge of it
- And finally, do some revision with other members of the class!

Important notice!

重要通知！

When I taught the previous Engineering course in May, the results were delayed. When you take the exam, please ensure that you clearly mark your English name, Chinese name and student number on the exam paper.

This will expedite marking (and hence results!) for all.

Many thanks.

当我在五月份教授之前的工程课程时，结果延迟了。参加考试时，请确保在试卷上清楚地标明自己的英文姓名、中文姓名和学号。

这将加快所有人的标记（以及结果！）。

非常感谢。

New information

- Any new announcements which I become aware of during the progress of the course will be published here.

New information